

***DeltaSpan™
Pultruded Grating***

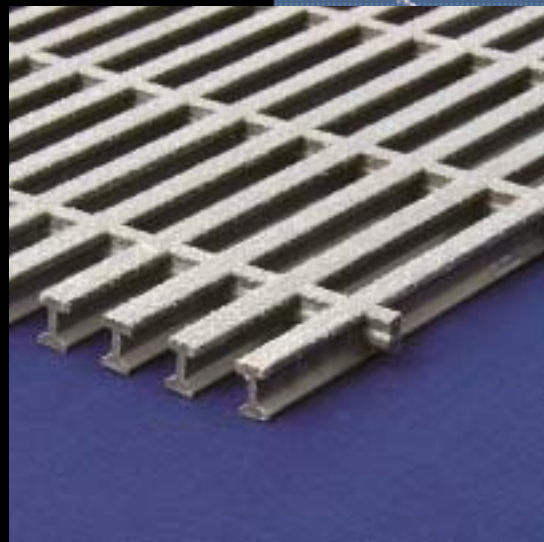
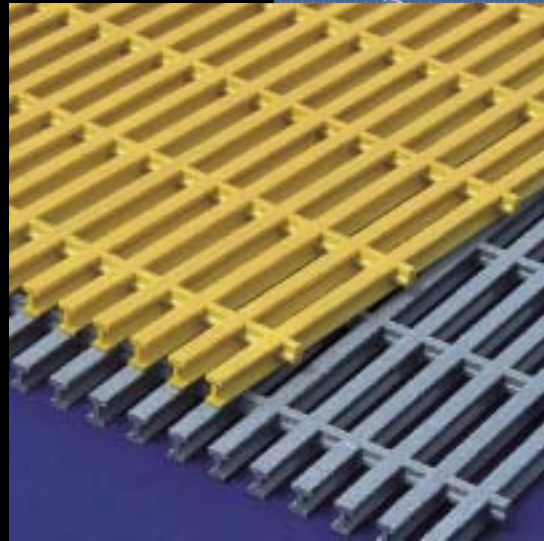

Delta Composites, LLC.

Table of Contents

DeltaSpan™ Pultruded Grating	2
Grating Selection Table	4
Resin Selection	5
Installation Accessories	6
Load Tables	
DeltaSpan™ Pultruded Grating - I-Beams	7
DeltaSpan™ Pultruded Grating - T-Beams	12
Field Fabrication & Installation of DeltaSpan™ Grating	14

DeltaSpan™ Pultruded Grating

DeltaSpan™ Pultruded Grating is manufactured with every panel of grating subjected to a sequence of quality assurance inspections ensuring complete sealing of all joints, full wet-out of the glass rovings, consistent resin-to-glass ratios, and consistent non-skid features. Complete traceability of resin batches and glass utilized in every panel is standard operating procedure. Records can be provided upon request.

DeltaSpan™ Pultruded Grating is lightweight, strong, chemical and U-V resistant, and reduces costly maintenance. DeltaSpan™ is particularly well suited for highly corrosive environments and offers extended life, eliminating periodic maintenance and replacement costs, thus making DeltaSpan™ Pultruded Gratings the preferred alternative to conventional steel gratings.

DeltaSpan™ Features and Options

Higher Stiffness

DeltaSpan™ Pultruded Grating possesses approximately 65% resin and 35% glass content by weight, giving it the very high strength to weight ratio. Load bearing bar capacity can be tailored to the application by modifying the glass content, fiber orientation, and combination of mat and roving reinforcement.

Chemical Resistance

DeltaSpan™ Pultruded Gratings offer superb chemical resistance to variety of acids and caustics. DeltaSpan™ is offered in an array of corrosion resistant resins designed for any environment, from light or moderately corrosive environments to extremely corrosive applications. DeltaSpan™ is offered in either premium isophthalic polyester, vinyl ester, or phenolic resins.



Lightweight

DeltaSpan™ Pultruded Gratings weigh much less than comparable steel gratings -- as much as 50% - 75% weight savings can be realized depending on the bearing bar configuration. For weight sensitive structures, such as a tension-leg platform (TLP) for an offshore deepwater facility, the use of DeltaSpan™ pultruded grating offers significant weight savings, thereby reducing the overall cost of the project.

Ultra-violet Resistance

All DeltaSpan™ Pultruded Gratings are manufactured with resins containing UV inhibitors. UV resistance is enhanced with the use of a synthetic surfacing veil, creating a "resin-rich" surface, and further strengthening DeltaSpan's™ resistance to ultra-violet attack. For optimum UV resistance, DeltaSpan™ can be coated for custom orders.

Impact Resistance

DeltaSpan™ Pultruded Gratings offer better impact resistance than conventional steel gratings.

Fire Retardancy

All DeltaSpan™ Pultruded Gratings are designed to exhibit a flame spread rating of 25 or less when tested in accordance with ASTM E-84 Tunnel Test, comparable to UL 723, ANSI/NFPA No. 255 and UBC No. 8-1, and meet the self-extinguishing requirements of ASTM D-685. A variety of resins are available offering an array of flame spread ratings and smoke densities, from as low as a flame spread of 4 and smoke density of 1 with our U.S. Coast Guard phenolic grating, DeltaSpan™ CG.

Non-Skid and Safety

All DeltaSpan™ Pultruded Gratings are equipped with a durable and permanent gritted surface on the topside of all bearing bars, thus providing superior slip resistance as compared to traditional steel grated walking surfaces.

Thermally and Electrically Non-Conductivity

DeltaSpan™ is both thermally and electrically non-conductive, two features that make it a desirable product in many applications such as those involving electrical and fire hazards. The thermal non-conductivity feature of DeltaSpan™ protects individuals from the heat radiation that occurs on traditional steel grating during fires --- firefighters can get, and stay closer to the fire source for longer periods of time.

Low Maintenance/Maintenance Free

With resin and pigment blended throughout DeltaSpan™ Pultruded Grating, you never need to coat or paint the product - - it simply does not rust. Coupled with our 316 stainless steel attachment systems, DeltaSpan™ offers "maintenance-free" walkway systems. **You install it and forget about it!!**

Industries Using Fiberglass Grating

- Offshore & Marine
- Petro-chemical & Refining
- Communications
- Water/Wastewater
- Transportation & Transit
- Aerospace
- Automotive
- Pulp & Paper
- Mining
- Metal Plating
- Food & Beverage
- Textile
- Electrical & Power Generation
- Computer and Hi-tech
- Recreational Water Parks & Pools
- Zoos and Aquariums
- Military
- Medical
- Shipping
- Many others

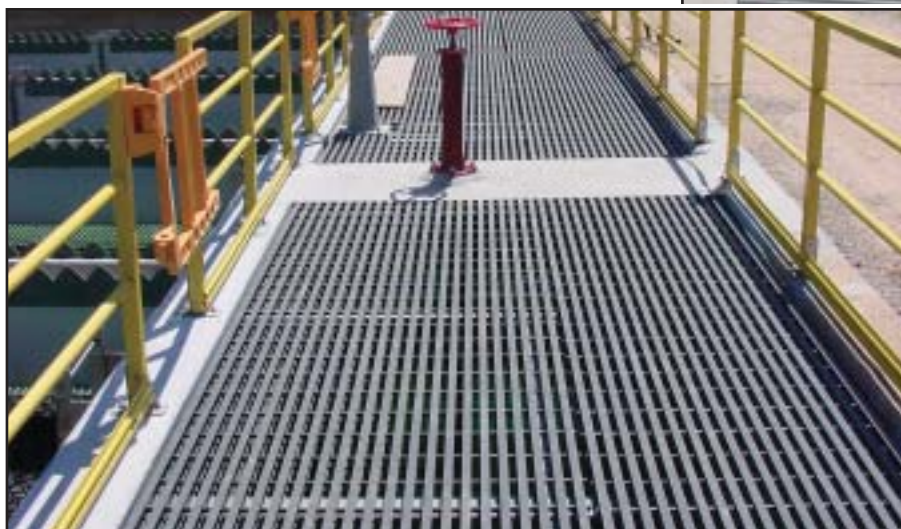

Grating Selection

Delta Composites offers both molded and pultruded gratings. The following table provides assistance in selecting the best grating for the application.

DeltaGrate™ HS Molded Grating vs. DeltaSpan™ Pultruded Grating		
Characteristic/Application	Square Mesh Molded Grating	Pultruded Grating
Chemical Resistance	Excellent	Good
Bi-directional Strength	Excellent	Not Recommended
Uni-directional Strength	Very Good	Excellent
Impact Resistance	Excellent	Average
Weight Savings versus Metal	Excellent	Excellent
Open Area (air flow, light penetration)	Excellent (70% to 80%)	Good (40% to 60%)
Panel Sizes Available	Excellent	Excellent
Pipe Penetrations	Excellent	Average
Safety	Excellent	Excellent

For any applications requiring our molded fiberglass gratings, please see the DeltaGrate™ HS Molded Fiberglass Grating brochure for additional information.

DeltaSpan™ Pultruded Grating Sizes and Specifications					
Grating Thickness	Mesh Description	Bars/ft	Panel Sizes Available	Weight (psf)	% Open Area
1"	1" I-Beam, I4010	12	3', 4', 5'* - widths 8', 10', 12', 20' - lengths	3.52	40%
1"	1" I-Beam, I5010**	10	3', 4', 5'* - widths 8', 10', 12', 20' - lengths	2.97	50%
1 1/2"	1 1/2" I-Beam, I4015	12	3', 4', 5'* - widths 8', 10', 12', 20' - lengths	4.21	40%
1 1/2"	1 1/2" I-Beam, I5015**	10	3', 4', 5'* - widths 8', 10', 12', 20' - lengths	3.54	50%
1 1/2"	1 1/2" I-Beam, I6015	8	3', 4', 5'* - widths 8', 10', 12', 20' - lengths	2.88	60%
2"	2" T-Beam, T3320	8	3', 4', 5'* - widths 8', 10', 12', 20' - lengths	3.90	33%
2"	2" T-Beam, T5020	6	3', 4', 5'* - widths 8', 10', 12', 20' - lengths	4.21	50%

*Note - 5' widths are non-stocked items. Please consult factory for delivery.

**Note - these items are non-stocked items. Please consult factory for delivery.

Resin Selection

Delta Composites manufactures pultruded grating in a variety of resins, each with its own unique performance characteristics. The resin selection is paramount in determining the corrosion resistance of the finished product. Please consult the Delta Composites Chemical Resistance Guide for assistance in selecting the proper resin for your application, or call Delta Composites' toll-free telephone number, 866-361-2100 for technical assistance.

Delta Composites' resin designations are comprised of two components: the resin type and its ASTM E-84 flame spread rating.



DeltaSpan™ VEFR-25 is a premium vinyl ester resin with a flame spread rating of 25 or less. DeltaSpan™ VEFR-25 pultruded grating is our most chemical resistant resin. Designed to withstand the harshest chemical environments over a broad range of acids and caustics, it is primarily used in petrochemical, waste water, mining, and plating applications where the grating is subject to frequent and direct contact with harsh chemicals. The standard color is yellow, but it is also available in dark gray.

DeltaSpan™ IFR-25 is a premium isophthalic polyester resin with a flame spread rating of 25 or less. DeltaSpan™ IFR-25 pultruded grating provides an intermediate level of chemical resistance and is the correct resin choice for grating subjected to splash and spill contact with harsh chemicals, and is a very good general purpose resin at a reduced cost compared to the premium vinyl ester resin. The standard color is yellow, but it is also available in dark gray.



Installation Accessories

INSTALLATION – whenever possible, provide for a minimum of 1-1/2" of bearing support at all grating support points. Holddown clips should be used at the rate of one clip for every 6 ft² of grating minimum, or at least 4 clips for any square or rectangular piece, or at least 3 for a triangular piece.

Grating Hold Down Clips for Pultruded Products

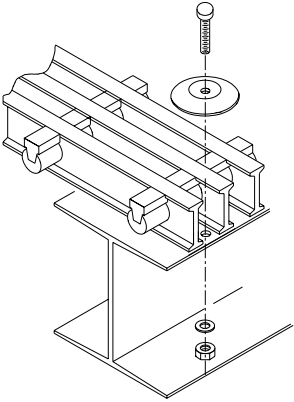
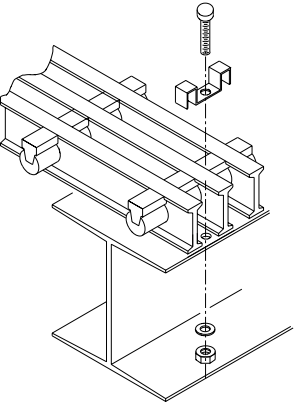
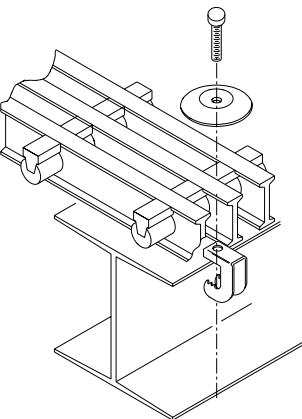
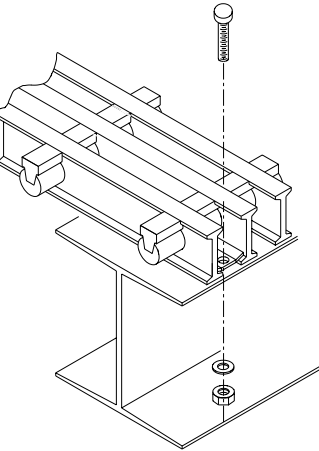
<p>Type WP</p>  <p>The diagram shows a cross-section of a pultruded grating bar being secured to a support structure. A hold-down clip is positioned on top of the grating bar, and a bolt is inserted through the clip and the grating bar into the support structure. A dashed line indicates the vertical alignment of the bolt.</p>	<p>Type MP</p>  <p>The diagram shows a cross-section of a pultruded grating bar being secured to a support structure. A hold-down clip is positioned on top of the grating bar, and a bolt is inserted through the clip and the grating bar into the support structure. A dashed line indicates the vertical alignment of the bolt.</p>
<p>Type GP</p>  <p>The diagram shows a cross-section of a pultruded grating bar being secured to a support structure. A hold-down clip is positioned on top of the grating bar, and a bolt is inserted through the clip and the grating bar into the support structure. A dashed line indicates the vertical alignment of the bolt.</p>	<p>Type PP</p>  <p>The diagram shows a cross-section of a pultruded grating bar being secured to a support structure. A hold-down clip is positioned on top of the grating bar, and a bolt is inserted through the clip and the grating bar into the support structure. A dashed line indicates the vertical alignment of the bolt.</p>

Load Tables

DeltaSpan™ Pultruded Grating - 1" I-Beam

I-4010 Technical Information

Bearing Bar Type	I-Bar
Open Area	40%
Thickness	1.0"
Bearing Bar Centers	1.0"
Resin Systems	IFR, VFR
Colors	Yellow or Gray
Approx. Weight	3.52 lbs/sq ft-12" Cross Rods 3.75 lbs/sq ft-6" Cross Rods

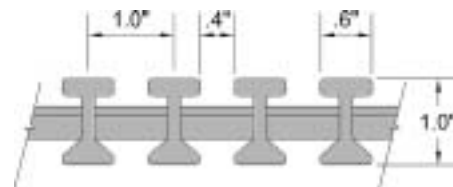

Span Inches	Load Type												Ultimate Load	
		100	200	300	400	500	750	1000	1500	2000	3000	4000		
18	UL													10080
	UL deflection	0.006	0.012	0.018	0.024	0.029	0.044	0.059	0.088	0.118	0.177	0.236		
	CL													13399
	CL deflection	0.007	0.013	0.020	0.027	0.033	0.050	0.067	0.100	0.133	0.200	0.266		
24	UL													7560
	UL deflection	0.017	0.034	0.050	0.067	0.084	0.126	0.168	0.252	0.336	0.503	0.671		
	CL													10049
	CL deflection	0.014	0.028	0.042	0.056	0.070	0.104	0.139	0.209	0.278	0.417	0.557		
30	UL													6048
	UL deflection	0.039	0.078	0.117	0.155	0.194	0.291	0.389	0.583	0.777	1.166	1.555		
	CL													8039
	CL deflection	0.026	0.051	0.077	0.102	0.128	0.191	0.255	0.383	0.510	0.765	1.020		
36	UL													4466
	UL deflection	0.078	0.156	0.235	0.313	0.391	0.587	0.782	1.174	1.565	2.347	3.129		
	CL													6699
	CL deflection	0.043	0.085	0.128	0.170	0.213	0.319	0.425	0.638	0.850	1.275	1.700		
42	UL													3281
	UL deflection	0.142	0.285	0.427	0.569	0.712	1.067	1.423	2.135	2.846	4.269			
	CL													5742
	CL deflection	0.066	0.132	0.198	0.264	0.330	0.495	0.660	0.990	1.320	1.980	2.640		
48	UL													2512
	UL deflection	0.240	0.480	0.720	0.959	1.199	1.799	2.399	3.598	4.797				
	CL													5025
	CL deflection	0.097	0.194	0.291	0.388	0.485	0.728	0.970	1.456	1.941	2.911	3.882		
54	UL													1985
	UL deflection	0.381	0.762	1.143	1.524	1.905	2.858	3.810	5.715					
	CL													4466
	CL deflection	0.137	0.273	0.410	0.547	0.684	1.026	1.367	2.051	2.735	4.102	5.470		
60	UL													1608
	UL deflection	0.577	1.154	1.732	2.309	2.886	4.329	5.772	8.658					
	CL													4020
	CL deflection	0.186	0.372	0.559	0.745	0.931	1.396	1.862	2.793	3.724	5.586	7.448		

Notes: Maximum allowable load is determined by a 2.5 safety factor in flexure and a 3.0 safety factor in shear.

Load and deflection data was derived from lab tests. Values tabled are for design selection and are not intended to be exact. Delta recommends selecting gratings based on a deflection of .25-inch or less. This deflection may be exceeded at the discretion of the designer. Deflections of .25-inch or less will give excellent pedestrian comfort. Deflections of .375-inch or less will give satisfactory pedestrian comfort. Data based on 12" cross rod and spacing.

The Load/Deflection values given in this brochure are median values. The manufacturing control limits on stiffness for all panes are plus or minus 10% of these median values.

Installation should provide for fully supported abutments of grating panels. Otherwise, higher deflection values may be experienced, and tripping hazards may occur. Stub bars should not be less than 1" in clip attachment areas. DeltaSpan pedestrian grating load bars at platform edges should be fully supported.

Load Tables

DeltaSpan™ Pultruded Grating - 1" I-Beam

I-5010 Technical Information

Bearing Bar Type	I-Beam
Open Area	50%
Thickness	1.0"
Bearing Bar Centers	1.20"
Resin Systems	IFR, VFR
Colors	Yellow or Gray
Approx. Weight	2.97 lbs/sq ft-12" Cross Rods 3.02 lbs/sq ft-6" Cross Rods

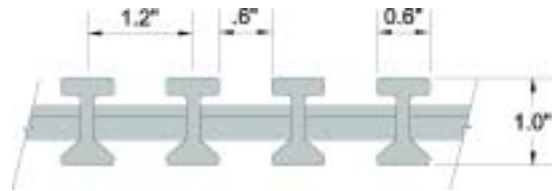

Span Inches	Load Type												Ultimate Load
18	UL	100	200	300	400	500	750	1000	1500	2000	3000	4000	8400
	UL deflection	0.007	0.014	0.021	0.028	0.035	0.053	0.071	0.106	0.141	0.212	0.283	
	CL	100	200	300	400	500	750	1000	1500	2000	3000	4000	11166
	CL deflection	0.008	0.016	0.024	0.032	0.040	0.060	0.080	0.120	0.160	0.239	0.319	
24	UL	100	200	300	400	500	750	1000	1500	2000	3000	4000	6300
	UL deflection	0.020	0.040	0.060	0.081	0.101	0.151	0.201	0.302	0.403	0.604	0.805	
	CL	100	200	300	400	500	750	1000	1500	2000	3000	4000	8374
	CL deflection	0.017	0.033	0.050	0.067	0.083	0.125	0.167	0.250	0.334	0.501	0.668	
30	UL	100	200	300	400	500	750	1000	1500	2000	3000	4000	5040
	UL deflection	0.047	0.093	0.140	0.187	0.233	0.350	0.466	0.700	0.933	1.399	1.866	
	CL	100	200	300	400	500	750	1000	1500	2000	3000	4000	6699
	CL deflection	0.031	0.061	0.092	0.122	0.153	0.230	0.306	0.459	0.612	0.918	1.224	
36	UL	100	200	300	400	500	750	1000	1500	2000	3000		3722
	UL deflection	0.094	0.188	0.282	0.376	0.469	0.704	0.939	1.408	1.878	2.817		
	CL	100	200	300	400	500	750	1000	1500	2000	3000	4000	5583
	CL deflection	0.051	0.102	0.153	0.204	0.255	0.383	0.510	0.765	1.020	1.530	2.040	
42	UL	100	200	300	400	500	750	1000	1500	2000			2734
	UL deflection	0.171	0.342	0.512	0.683	0.854	1.281	1.708	2.562	3.415			
	CL	100	200	300	400	500	750	1000	1500	2000	3000	4000	4785
	CL deflection	0.079	0.158	0.238	0.317	0.396	0.594	0.792	1.188	1.584	2.376	3.167	
48	UL	100	200	300	400	500	750	1000	1500	2000			2094
	UL deflection	0.288	0.576	0.863	1.151	1.439	2.159	2.878	4.317	5.757			
	CL	100	200	300	400	500	750	1000	1500	2000	3000	4000	4187
	CL deflection	0.116	0.233	0.349	0.466	0.582	0.873	1.165	1.747	2.329	3.494	4.658	
54	UL	100	200	300	400	500	750	1000	1500				1654
	UL deflection	0.457	0.914	1.372	1.829	2.286	3.429	4.572	6.858				
	CL	100	200	300	400	500	750	1000	1500	2000	3000		3722
	CL deflection	0.164	0.328	0.492	0.656	0.820	1.231	1.641	2.461	3.282	4.923		
60	UL	100	200	300	400	500	750	1000					1340
	UL deflection	0.693	1.385	2.078	2.771	3.463	5.195	6.927					
	CL	100	200	300	400	500	750	1000	1500	2000	3000		3350
	CL deflection	0.223	0.447	0.670	0.894	1.117	1.676	2.234	3.351	4.469	6.703		

Notes: Maximum allowable load is determined by a 2.5 safety factor in flexure and a 3.0 safety factor in shear.

Load and deflection data was derived from lab tests. Values tabled are for design selection and are not intended to be exact. Delta recommends selecting gratings based on a deflection of .25-inch or less. This deflection may be exceeded at the discretion of the designer. Deflections of .25-inch or less will give excellent pedestrian comfort. Deflections of .375-inch or less will give satisfactory pedestrian comfort. Data based on 12" cross rod and spacing.

The Load/Deflection values given in this brochure are median values. The manufacturing control limits on stiffness for all panes are plus or minus 10% of these median values.

Installation should provide for fully supported abutments of grating panels. Otherwise, higher deflection values may be experienced, and tripping hazards may occur. Stub bars should not be less than 1" in clip attachment areas. DeltaSpan pedestrian grating load bars at platform edges should be fully supported.

Load Tables

DeltaSpan™ Pultruded Grating - 1-1/2" I-Beam

I-4015 Technical Information

Bearing Bar Type	I-Bar
Open Area	40%
Thickness	1.5"
Bearing Bar Centers	1.0"
Resin Systems	IFR, VFR
Colors	Yellow or Gray
Approx. Weight	4.21 lbs/sq ft-12" Cross Rods
	4.44 lbs/sq ft-6" Cross Rods

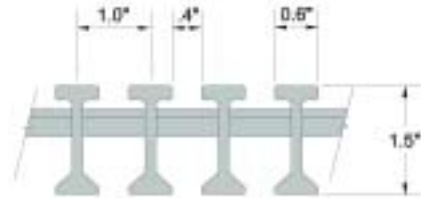

Span Inches	Load Type												Ultimate Load
		100	200	300	400	500	750	1000	1500	2000	3000	4000	
18	UL	100	200	300	400	500	750	1000	1500	2000	3000	4000	15120
	UL deflection	0.002	0.005	0.007	0.010	0.012	0.018	0.024	0.037	0.049	0.073	0.097	
	CL	100	200	300	400	500	750	1000	1500	2000	3000	4000	22680
	CL deflection	0.003	0.006	0.009	0.011	0.014	0.021	0.028	0.043	0.057	0.085	0.114	
24	UL	100	200	300	400	500	750	1000	1500	2000	3000	4000	11340
	UL deflection	0.006	0.013	0.019	0.026	0.032	0.048	0.065	0.097	0.129	0.194	0.258	
	CL	100	200	300	400	500	750	1000	1500	2000	3000	4000	19084
	CL deflection	0.005	0.011	0.016	0.022	0.027	0.041	0.055	0.082	0.110	0.165	0.220	
30	UL	100	200	300	400	500	750	1000	1500	2000	3000	4000	9072
	UL deflection	0.014	0.029	0.043	0.058	0.072	0.108	0.144	0.216	0.288	0.431	0.575	
	CL	100	200	300	400	500	750	1000	1500	2000	3000	4000	15267
	CL deflection	0.010	0.019	0.029	0.038	0.048	0.072	0.096	0.144	0.192	0.288	0.384	
36	UL	100	200	300	400	500	750	1000	1500	2000	3000	4000	7560
	UL deflection	0.028	0.056	0.085	0.113	0.141	0.212	0.282	0.424	0.565	0.847	1.130	
	CL	100	200	300	400	500	750	1000	1500	2000	3000	4000	12723
	CL deflection	0.016	0.031	0.047	0.062	0.078	0.117	0.156	0.233	0.311	0.467	0.622	
42	UL	100	200	300	400	500	750	1000	1500	2000	3000	4000	6232
	UL deflection	0.051	0.101	0.152	0.202	0.253	0.379	0.506	0.758	1.011	1.517	2.022	
	CL	100	200	300	400	500	750	1000	1500	2000	3000	4000	10905
	CL deflection	0.024	0.047	0.071	0.095	0.119	0.178	0.237	0.356	0.474	0.711	0.948	
48	UL	100	200	300	400	500	750	1000	1500	2000	3000	4000	4771
	UL deflection	0.084	0.169	0.253	0.337	0.422	0.632	0.843	1.265	1.686	2.529	3.372	
	CL	100	200	300	400	500	750	1000	1500	2000	3000	4000	9542
	CL deflection	0.034	0.069	0.103	0.138	0.172	0.258	0.344	0.516	0.688	1.032	1.376	
54	UL	100	200	300	400	500	750	1000	1500	2000	3000		3770
	UL deflection	0.133	0.266	0.399	0.532	0.665	0.997	1.329	1.994	2.658	3.987		
	CL	100	200	300	400	500	750	1000	1500	2000	3000	4000	8482
	CL deflection	0.048	0.096	0.144	0.192	0.240	0.360	0.480	0.721	0.961	1.441	1.922	
60	UL	100	200	300	400	500	750	1000	1500	2000	3000		3053
	UL deflection	0.200	0.401	0.601	0.801	1.001	1.502	2.003	3.004	4.005	6.008		
	CL	100	200	300	400	500	750	1000	1500	2000	3000	4000	7634
	CL deflection	0.065	0.130	0.195	0.260	0.325	0.487	0.650	0.975	1.299	1.949	2.599	

Notes: Maximum allowable load is determined by a 2.5 safety factor in flexure and a 3.0 safety factor in shear.

Load and deflection data was derived from lab tests. Values tabled are for design selection and are not intended to be exact. Delta recommends selecting gratings based on a deflection of .25-inch or less. This deflection may be exceeded at the discretion of the designer. Deflections of .25-inch or less will give excellent pedestrian comfort. Deflections of .375-inch or less will give satisfactory pedestrian comfort. Data based on 12" cross rod and spacing.

The Load/Deflection values given in this brochure are median values. The manufacturing control limits on stiffness for all panes are plus or minus 10% of these median values.

Installation should provide for fully supported abutments of grating panels. Otherwise, higher deflection values may be experienced, and tripping hazards may occur. Stub bars should not be less than 1" in clip attachment areas. DeltaSpan pedestrian grating load bars at platform edges should be fully supported.

Load Tables

DeltaSpan™ Pultruded Grating - 1-1/2" I-Beam

I-5015 Technical Information

Bearing Bar Type	I-Bar
Open Area	50%
Thickness	1.5"
Bearing Bar Centers	1.20"
Resin Systems	IFR, VFR
Colors	Yellow or Gray
Approx. Weight	3.54 lbs/sq ft-12" Cross Rods
	3.77 lbs/sq ft-6" Cross Rods

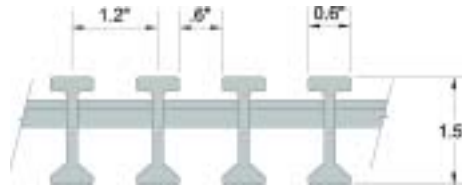

Span Inches	Load Type												Ultimate Load
18	UL	100	200	300	400	500	750	1000	1500	2000	3000	4000	12600
	UL deflection	0.003	0.006	0.009	0.012	0.015	0.022	0.029	0.044	0.058	0.088	0.117	
	CL	100	200	300	400	500	750	1000	1500	2000	3000	4000	18900
	CL deflection	0.003	0.007	0.010	0.014	0.017	0.026	0.034	0.051	0.068	0.102	0.136	
24	UL	100	200	300	400	500	750	1000	1500	2000	3000	4000	9450
	UL deflection	0.008	0.016	0.023	0.031	0.039	0.058	0.078	0.116	0.155	0.233	0.310	
	CL	100	200	300	400	500	750	1000	1500	2000	3000	4000	15903
	CL deflection	0.007	0.013	0.020	0.026	0.033	0.049	0.066	0.099	0.132	0.198	0.264	
30	UL	100	200	300	400	500	750	1000	1500	2000	3000	4000	7560
	UL deflection	0.017	0.035	0.052	0.069	0.086	0.129	0.173	0.259	0.345	0.518	0.690	
	CL	100	200	300	400	500	750	1000	1500	2000	3000	4000	12723
	CL deflection	0.012	0.023	0.035	0.046	0.058	0.086	0.115	0.173	0.231	0.346	0.461	
36	UL	100	200	300	400	500	750	1000	1500	2000	3000	4000	6300
	UL deflection	0.034	0.068	0.102	0.136	0.169	0.254	0.339	0.508	0.678	1.017	1.355	
	CL	100	200	300	400	500	750	1000	1500	2000	3000	4000	10602
	CL deflection	0.019	0.037	0.056	0.075	0.093	0.140	0.187	0.280	0.373	0.560	0.747	
42	UL	100	200	300	400	500	750	1000	1500	2000	3000	4000	5193
	UL deflection	0.061	0.121	0.182	0.243	0.303	0.455	0.607	0.910	1.213	1.820	2.427	
	CL	100	200	300	400	500	750	1000	1500	2000	3000	4000	9088
	CL deflection	0.028	0.057	0.085	0.114	0.142	0.213	0.284	0.427	0.569	0.853	1.138	
48	UL	100	200	300	400	500	750	1000	1500	2000	3000		3976
	UL deflection	0.101	0.202	0.304	0.405	0.506	0.759	1.012	1.518	2.023	3.035		
	CL	100	200	300	400	500	750	1000	1500	2000	3000	4000	7952
	CL deflection	0.041	0.083	0.124	0.165	0.206	0.310	0.413	0.619	0.826	1.239	1.652	
54	UL	100	200	300	400	500	750	1000	1500	2000	3000		3141
	UL deflection	0.159	0.319	0.478	0.638	0.797	1.196	1.595	2.392	3.190	4.785		
	CL	100	200	300	400	500	750	1000	1500	2000	3000	4000	7068
	CL deflection	0.058	0.115	0.173	0.231	0.288	0.432	0.577	0.865	1.153	1.730	2.306	
60	UL	100	200	300	400	500	750	1000	1500	2000			2545
	UL deflection	0.240	0.481	0.721	0.961	1.202	1.802	2.403	3.605	4.806			
	CL	100	200	300	400	500	750	1000	1500	2000	3000	4000	6361
	CL deflection	0.078	0.156	0.234	0.312	0.390	0.585	0.780	1.169	1.559	2.339	3.119	

Notes: Maximum allowable load is determined by a 2.5 safety factor in flexure and a 3.0 safety factor in shear.

Load and deflection data was derived from lab tests. Values tabled are for design selection and are not intended to be exact. Delta recommends selecting gratings based on a deflection of .25-inch or less. This deflection may be exceeded at the discretion of the designer. Deflections of .25-inch or less will give excellent pedestrian comfort. Deflections of .375-inch or less will give satisfactory pedestrian comfort. Data based on 12" cross rod and spacing.

The Load/Deflection values given in this brochure are median values. The manufacturing control limits on stiffness for all panes are plus or minus 10% of these median values.

Installation should provide for fully supported abutments of grating panels. Otherwise, higher deflection values may be experienced, and tripping hazards may occur. Stub bars should not be less than 1" in clip attachment areas. DeltaSpan pedestrian grating load bars at platform edges should be fully supported.

Load Tables

DeltaSpan™ Pultruded Grating - 1-1/2" I-Beam

I-6015 Technical Information

Bearing Bar Type	I-Beam
Open Area	60%
Thickness	1.5"
Bearing Bar Centers	1.5"
Resin Systems	IFR, VFR
Colors	Yellow or Gray
Approx. Weight	2.88 lbs/sq ft-12" Cross Rods 3.11 lbs/sq ft-6" Cross Rods

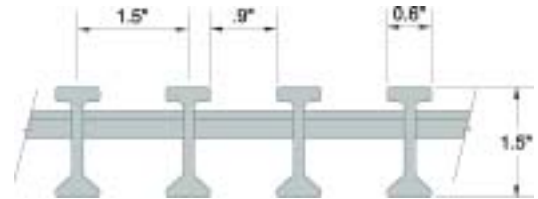

Span Inches	Load Type												Ultimate Load
18	UL	0.004	0.007	0.011	0.015	0.018	0.027	0.037	0.055	0.073	0.110	0.146	10080
	UL deflection	100	200	300	400	500	750	1000	1500	2000	3000	4000	
	CL	0.004	0.009	0.013	0.017	0.021	0.032	0.043	0.064	0.085	0.128	0.170	15120
	CL deflection	100	200	300	400	500	750	1000	1500	2000	3000	4000	
24	UL	0.010	0.019	0.029	0.039	0.048	0.073	0.097	0.145	0.194	0.291	0.388	7560
	UL deflection	100	200	300	400	500	750	1000	1500	2000	3000	4000	
	CL	0.008	0.016	0.025	0.033	0.041	0.062	0.082	0.124	0.165	0.247	0.329	12723
	CL deflection	100	200	300	400	500	750	1000	1500	2000	3000	4000	
30	UL	0.022	0.043	0.065	0.086	0.108	0.162	0.216	0.323	0.431	0.647	0.863	6048
	UL deflection	100	200	300	400	500	750	1000	1500	2000	3000	4000	
	CL	0.014	0.029	0.043	0.058	0.072	0.108	0.144	0.216	0.288	0.432	0.577	10178
	CL deflection	100	200	300	400	500	750	1000	1500	2000	3000	4000	
36	UL	0.042	0.085	0.127	0.169	0.212	0.318	0.424	0.635	0.847	1.271	1.694	5040
	UL deflection	100	200	300	400	500	750	1000	1500	2000	3000	4000	
	CL	0.023	0.047	0.070	0.093	0.117	0.175	0.233	0.350	0.467	0.700	0.933	8482
	CL deflection	100	200	300	400	500	750	1000	1500	2000	3000	4000	
42	UL	0.076	0.152	0.228	0.303	0.379	0.569	0.758	1.138	1.517	2.275	3.034	4154
	UL deflection	100	200	300	400	500	750	1000	1500	2000	3000	4000	
	CL	0.036	0.071	0.107	0.142	0.178	0.267	0.356	0.533	0.711	1.067	1.422	7270
	CL deflection	100	200	300	400	500	750	1000	1500	2000	3000	4000	
48	UL	0.126	0.253	0.379	0.506	0.632	0.948	1.265	1.897	2.529	3.794		3181
	UL deflection	100	200	300	400	500	750	1000	1500	2000	3000		
	CL	0.052	0.103	0.155	0.206	0.258	0.387	0.516	0.774	1.032	1.548	2.065	6361
	CL deflection	100	200	300	400	500	750	1000	1500	2000	3000	4000	
54	UL	0.199	0.399	0.598	0.797	0.997	1.495	1.994	2.991	3.987			2513
	UL deflection	100	200	300	400	500	750	1000	1500	2000			
	CL	0.072	0.144	0.216	0.288	0.360	0.540	0.721	1.081	1.441	2.162	2.883	5655
	CL deflection	100	200	300	400	500	750	1000	1500	2000	3000	4000	
60	UL	0.300	0.601	0.901	1.202	1.502	2.253	3.004	4.506	6.008			2036
	UL deflection	100	200	300	400	500	750	1000	1500	2000			
	CL	0.097	0.195	0.292	0.390	0.487	0.731	0.975	1.462	1.949	2.924	3.898	5089
	CL deflection	100	200	300	400	500	750	1000	1500	2000	3000	4000	

Notes: Maximum allowable load is determined by a 2.5 safety factor in flexure and a 3.0 safety factor in shear.

Load and deflection data was derived from lab tests. Values tabled are for design selection and are not intended to be exact. Delta recommends selecting gratings based on a deflection of .25-inch or less. This deflection may be exceeded at the discretion of the designer. Deflections of .25-inch or less will give excellent pedestrian comfort. Deflections of .375-inch or less will give satisfactory pedestrian comfort. Data based on 12" cross rod and spacing.

The Load/Deflection values given in this brochure are median values. The manufacturing control limits on stiffness for all panes are plus or minus 10% of these median values.

Installation should provide for fully supported abutments of grating panels. Otherwise, higher deflection values may be experienced, and tripping hazards may occur. Stub bars should not be less than 1" in clip attachment areas. DeltaSpan pedestrian grating load bars at platform edges should be fully supported.

Load Tables

DeltaSpan™ Pultruded Grating - 2" T-Beam

T-3320 Technical Information

Bearing Bar Type	T-Bar
Open Area	33%
Thickness	2.0"
Bearing Bar Centers	1.5"
Resin Systems	IFR, VFR
Colors	Yellow or Gray
Approx. Weight	3.90 lbs/sq ft-12" Cross Rods 4.13 lbs/sq ft-6" Cross Rods

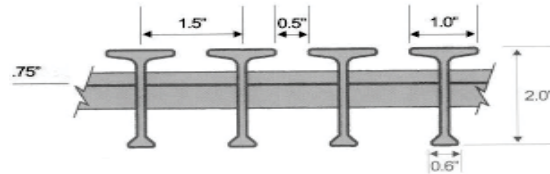

Span Inches	Load Type												Ultimate Load
24	UL	100	200	300	400	500	750	1000	1500	2000	3000	4000	10080
	UL deflection	0.005	0.010	0.015	0.020	0.025	0.037	0.049	0.074	0.098	0.147	0.196	
	CL	100	200	300	400	500	750	1000	1500	2000	3000	4000	17056
	CL deflection	0.004	0.009	0.013	0.017	0.021	0.032	0.043	0.064	0.086	0.129	0.171	
30	UL	100	200	300	400	500	750	1000	1500	2000	3000	4000	8064
	UL deflection	0.010	0.021	0.031	0.042	0.052	0.078	0.104	0.156	0.208	0.312	0.416	
	CL	100	200	300	400	500	750	1000	1500	2000	3000	4000	13645
	CL deflection	0.007	0.014	0.021	0.028	0.036	0.053	0.071	0.107	0.142	0.213	0.285	
36	UL	100	200	300	400	500	750	1000	1500	2000	3000	4000	6720
	UL deflection	0.020	0.040	0.059	0.079	0.099	0.149	0.198	0.297	0.396	0.594	0.793	
	CL	100	200	300	400	500	750	1000	1500	2000	3000	4000	11371
	CL deflection	0.011	0.022	0.033	0.044	0.056	0.083	0.111	0.167	0.222	0.334	0.445	
42	UL	100	200	300	400	500	750	1000	1500	2000	3000	4000	5569
	UL deflection	0.035	0.069	0.104	0.139	0.174	0.261	0.347	0.521	0.695	1.042	1.389	
	CL	100	200	300	400	500	750	1000	1500	2000	3000	4000	9746
	CL deflection	0.017	0.033	0.050	0.066	0.083	0.124	0.165	0.248	0.331	0.496	0.661	
48	UL	100	200	300	400	500	750	1000	1500	2000	3000	4000	4264
	UL deflection	0.057	0.114	0.171	0.228	0.285	0.428	0.571	0.856	1.141	1.712	2.283	
	CL	100	200	300	400	500	750	1000	1500	2000	3000	4000	8528
	CL deflection	0.024	0.047	0.071	0.094	0.118	0.177	0.236	0.354	0.471	0.707	0.943	
54	UL	100	200	300	400	500	750	1000	1500	2000	3000		3369
	UL deflection	0.089	0.178	0.267	0.356	0.445	0.668	0.890	1.335	1.780	2.670		
	CL	100	200	300	400	500	750	1000	1500	2000	3000	4000	7580
	CL deflection	0.032	0.065	0.097	0.130	0.162	0.244	0.325	0.487	0.650	0.975	1.300	
60	UL	100	200	300	400	500	750	1000	1500	2000			2729
	UL deflection	0.133	0.266	0.399	0.532	0.665	0.998	1.331	1.996	2.661			
	CL	100	200	300	400	500	750	1000	1500	2000	3000	4000	6822
	CL deflection	0.044	0.087	0.131	0.174	0.218	0.326	0.435	0.653	0.871	1.306	1.741	
66	UL	100	200	300	400	500	750	1000	1500	2000			2255
	UL deflection	0.192	0.384	0.576	0.768	0.960	1.440	1.920	2.880	3.839			
	CL	100	200	300	400	500	750	1000	1500	2000	3000	4000	6202
	CL deflection	0.057	0.114	0.171	0.228	0.285	0.427	0.569	0.854	1.138	1.707	2.276	
72	UL	100	200	300	400	500	750	1000	1500				1895
	UL deflection	0.269	0.538	0.807	1.075	1.344	2.016	2.688	4.033				
	CL	100	200	300	400	500	750	1000	1500	2000	3000	4000	5685
	CL deflection	0.073	0.146	0.219	0.291	0.364	0.547	0.729	1.093	1.457	2.186	2.915	
78	UL	100	200	300	400	500	750	1000	1500				1615
	UL deflection	0.367	0.734	1.101	1.468	1.835	2.753	3.670	5.505				
	CL	100	200	300	400	500	750	1000	1500	2000	3000	4000	5248
	CL deflection	0.092	0.183	0.275	0.367	0.458	0.687	0.916	1.375	1.833	2.749	3.666	

Notes: Maximum allowable load is determined by a 2.5 safety factor in flexure and a 3.0 safety factor in shear.

The Load/Deflection values given in this brochure are median values. The manufacturing control limits on stiffness for all panes are plus or minus 10% of these median values.

Installation should provide for fully supported abutments of grating panels. Otherwise, higher deflection values may be experienced, and tripping hazards may occur. Stub bars should not be less than 1" in clip attachment areas. DeltaSpan pedestrian grating load bars at platform edges should be fully supported.

Load Tables

DeltaSpan™ Pultruded Grating - 2" T-Beam

T-5020 Technical Information

Bearing Bar Type T-Bar
Open Area 50%
Thickness 2.0"
Bearing Bar Centers 1.0"
Resin Systems IFR, VFR
Colors Yellow or Gray
Approx. Weight 4.21 lbs/sq ft-12" Cross Rods
 4.44 lbs/sq ft-6" Cross Rods

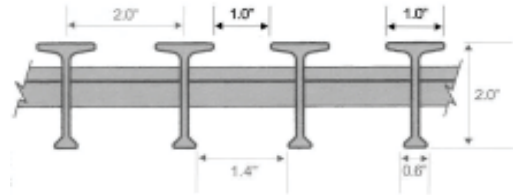

Span Inches	Load Type												Ultimate Load
24	UL	100	200	300	400	500	750	1000	1500	2000	3000	4000	7560
	UL deflection	0.007	0.013	0.020	0.026	0.033	0.049	0.065	0.098	0.131	0.196	0.262	
	CL	100	200	300	400	500	750	1000	1500	2000	3000	4000	12792
	CL deflection	0.006	0.011	0.017	0.023	0.029	0.043	0.057	0.086	0.114	0.171	0.229	
30	UL	100	200	300	400	500	750	1000	1500	2000	3000	4000	6048
	UL deflection	0.014	0.028	0.042	0.056	0.069	0.104	0.139	0.208	0.278	0.416	0.555	
	CL	100	200	300	400	500	750	1000	1500	2000	3000	4000	10234
	CL deflection	0.009	0.019	0.028	0.038	0.047	0.071	0.095	0.142	0.190	0.285	0.380	
36	UL	100	200	300	400	500	750	1000	1500	2000	3000	4000	5040
	UL deflection	0.026	0.053	0.079	0.106	0.132	0.198	0.264	0.396	0.528	0.793	1.057	
	CL	100	200	300	400	500	750	1000	1500	2000	3000	4000	8528
	CL deflection	0.015	0.030	0.044	0.059	0.074	0.111	0.148	0.222	0.296	0.445	0.593	
42	UL	100	200	300	400	500	750	1000	1500	2000	3000	4000	4177
	UL deflection	0.046	0.093	0.139	0.185	0.232	0.347	0.463	0.695	0.926	1.389	1.853	
	CL	100	200	300	400	500	750	1000	1500	2000	3000	4000	7310
	CL deflection	0.022	0.044	0.066	0.088	0.110	0.165	0.220	0.331	0.441	0.661	0.881	
48	UL	100	200	300	400	500	750	1000	1500	2000	3000		3198
	UL deflection	0.076	0.152	0.228	0.304	0.380	0.571	0.761	1.141	1.522	2.283		
	CL	100	200	300	400	500	750	1000	1500	2000	3000	4000	6396
	CL deflection	0.031	0.063	0.094	0.126	0.157	0.236	0.314	0.471	0.629	0.943	1.257	
54	UL	100	200	300	400	500	750	1000	1500	2000			2527
	UL deflection	0.119	0.237	0.356	0.475	0.593	0.890	1.187	1.780	2.374			
	CL	100	200	300	400	500	750	1000	1500	2000	3000	4000	5685
	CL deflection	0.043	0.087	0.130	0.173	0.217	0.325	0.433	0.650	0.867	1.300	1.733	
60	UL	100	200	300	400	500	750	1000	1500	2000			2047
	UL deflection	0.177	0.355	0.532	0.710	0.887	1.331	1.774	2.661	3.548			
	CL	100	200	300	400	500	750	1000	1500	2000	3000	4000	5117
	CL deflection	0.058	0.116	0.174	0.232	0.290	0.435	0.580	0.871	1.161	1.741	2.322	
66	UL	100	200	300	400	500	750	1000	1500				1692
	UL deflection	0.256	0.512	0.768	1.024	1.280	1.920	2.560	3.839				
	CL	100	200	300	400	500	750	1000	1500	2000	3000	4000	4652
	CL deflection	0.076	0.152	0.228	0.304	0.379	0.569	0.759	1.138	1.518	2.276	3.035	
72	UL	100	200	300	400	500	750	1000					1421
	UL deflection	0.358	0.717	1.075	1.434	1.792	2.688	3.584					
	CL	100	200	300	400	500	750	1000	1500	2000	3000	4000	4264
	CL deflection	0.097	0.194	0.291	0.389	0.486	0.729	0.972	1.457	1.943	2.915	3.886	
78	UL	100	200	300	400	500	750	1000					1211
	UL deflection	0.489	0.979	1.468	1.957	2.447	3.670	4.893					
	CL	100	200	300	400	500	750	1000	1500	2000	3000		3936
	CL deflection	0.122	0.244	0.367	0.489	0.611	0.916	1.222	1.833	2.444	3.666		

Notes: Maximum allowable load is determined by a 2.5 safety factor in flexure and a 3.0 safety factor in shear.

The Load/Deflection values given in this brochure are median values. The manufacturing control limits on stiffness for all panes are plus or minus 10% of these median values.

Installation should provide for fully supported abutments of grating panels. Otherwise, higher deflection values may be experienced, and tripping hazards may occur. Stub bars should not be less than 1" in clip attachment areas. DeltaSpan pedestrian grating load bars at platform edges should be fully supported.

Field Fabrication and Installation of DeltaSpan™ Pultruded Grating

SAFETY PRECAUTIONS -- When cutting DeltaSpan™ Pultruded Grating, always wear safety glasses or goggles to protect your eyes and always wear a dust mask to reduce dust inhalation. Always wear gloves, and it is recommended that a shop coat with neck and tapered sleeves be worn to prevent skin irritation. Work in well-lighted and ventilated area. Always read the MSDS (Material Safety Data Sheet) before cutting and sealing DeltaSpan™ Pultruded Grating. Always provide firm support of the grating panels to prevent shifting, and the use of sawhorses and other supports will help to prevent common back injuries. Cutting of DeltaSpan™ Pultruded Grating will produce dust -- this dust is non-carcinogenic but may cause some skin irritation.

CUTTING DELTASPAN™ PULTRUDED GRATING -- Depending on the amount (linear feet) of grating to be cut, and the type of cutting required, i.e., straight cuts or circular cuts, a variety of field and shop tools can be used such as an abrasive coated metal blade, or a standard bimetal blade or a hacksaw with a blade with a similar tooth pattern as the bimetal blade.

For making straight cuts, the following equipment is recommended:

- Panel saw*
- Circular saw*
- Table saw*
- Radial arm saw*
- Reciprocating saw (6" lg. abrasive coated or a bimetal blade, 12-14 teeth, min.)
- Hand-held hack saw (for small quantities or emergencies)
*The blade should be an abrasive continuous rim cut-off blade normally used on masonry or ceramic products (silica gritted or diamond coated blades).

Product Selection Ordering Guide

1. Determine the application of the Pultruded Grating.
2. Determine the physical requirements such as:
 - a) exposure to chemicals and/or extreme temperatures (see chart.)
 - b) fire retardance.
 - c) loading requirements, span, and support (see load chart.)
3. Choose Delta Composites' DeltaSpan™ Pultruded Fiberglass Grating.
4. Specify the style and resin:
 - a) bar type (I or T), size and spacing of bearing and crosses.
 - b) type of resin.
5. Determine width and length (length is always bearing bar length and width is end to end of the cross rod.)
6. Choose grit surface.
7. Choose Color.
8. Determine number of pieces required.

For making small radius circular cuts, a reciprocating saw with the same blade specifications above is recommended. For making larger radius circular cuts, a circular saw can be used using the blade specifications stated above.

Remember that the saw blades will "eat-up" about 1/8" of grating with each cut, so be sure to allow for this when measuring and laying out your marks on the grating panel.

Always use sandpaper or a sanding wheel to smooth out all cut edges before sealing and ALL CUT EDGES MUST BE SEALED. For this, use Delta Composites Zynolite, a premium grade exterior polyurethane enamel specially formulated to effectively seal cut surfaces of fiberglass products to protect the glass fibers from environmental attack. The material is supplied in 11 oz. spray cans and is to be used in accordance with the instructions on each can. The material dries in 30 minutes, and is non-toxic when dry. Delta Composites Zynolite is flammable and care must be taken to use the material and dispose of the material in accordance with the written instructions on each can.

Also available from Delta Composites

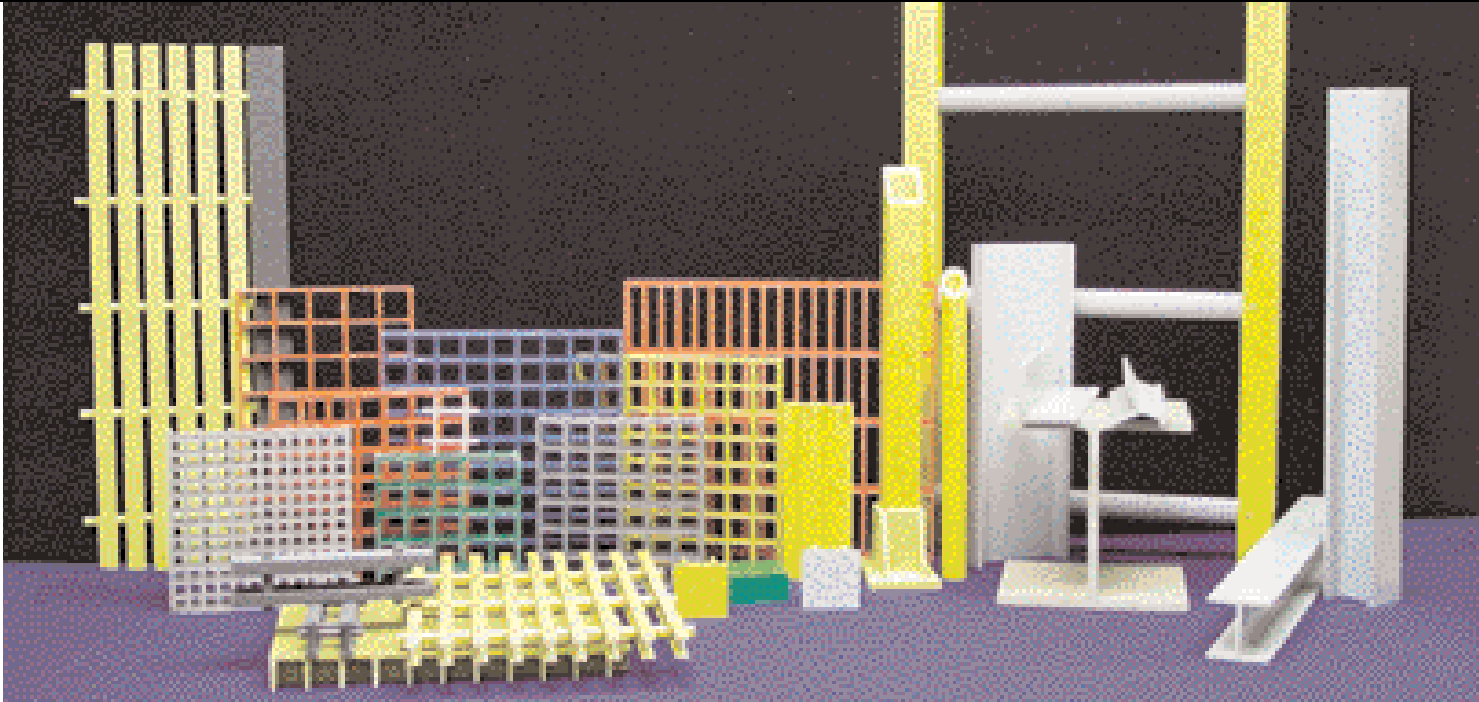

DeltaGrate™

High-Strength Molded Grating

Offers a higher glass content (38% by weight) than conventional molded gratings. The DeltaGrate family of products includes:

- DeltaGrate Mini-Mesh Grating
- DeltaGrate Conductive Molded Grating
- DeltaGrate Food-Grade FRP
- DeltaGrate Covered Plate Grating
- DeltaTread Stair Treads
- DeltaGrate Stair Tread Covers
- DeltaGrate Fluorescent Grating
- DeltaLite Grating
- DeltaScreen
- Grating Legs

DeltaRail™ & DeltaLadder™

Chemical and corrosion resistant fiberglass handrail and ladders. DeltaRail fiberglass handrail is available in two or three rail systems that can be either side mounted or top mounted. DeltaLadder fiberglass ladders and cages custom built to your requirements and prefabricated for easy installation.

DeltaTreads™

A safe and cost effective alternative to conventional steel stair treads. With a solid gritted nosing, DeltaTread is corrosion resistant, slip resistant, and stronger than other fiberglass stair treads. Fabricated molded square-mesh treads and pultruded stair treads are also available.

Stair Tread Covers

An efficient and cost effective solution to slippery and unsafe stairways. This safety product is typically installed over existing steel stair treads. Available in fluorescent colors for increased nighttime visibility and safety.

Delta Composites, L.L.C believes the information contained here to be true and accurate. Delta Composites makes no warranty, expressed or implied based on this literature and assumes no responsibility for consequential or incidental damages in the use of these products and systems described, including any warranty of merchantability or fitness. Information contained here is for evaluation only.



Delta Composites, L.L.C.

1611 Peachleaf Street
Houston, Texas 77039

281-449-4900
Toll-free: 866-361-2100
Fax: 281-449-4600
Email: sales@deltacomposites.com

www.deltacomposites.com

©2002 Delta Composites