



# Design Manual

Fiberglass Grating and Structural Products

# TABLE OF CONTENTS

SECTION 1	- Introduction.....	2
SECTION 2	- The Basics of Fiberglass Pultrusion .....	3
SECTION 3	- Structural Design Basis.....	8
SECTION 4	- Physical Properties for Designing with .....	13
	Fiberglass Structural Shapes	
SECTION 5	- Cross Sectional and Engineering Properties.....	23
	of Fiberglass Structural Shapes	
SECTION 6	- Safety Factors Used in Designing with .....	34
	Fiberglass Shapes	
SECTION 7	- Effects of Temperature on .....	36
	Fiberglass Structural Shapes	
SECTION 8	- Corrosion Guide for the Proper Selection of Resins .....	38
SECTION 9	- Designing Flexural Members (Beams).....	48
SECTION 10	- Designing Tension Members.....	55
SECTION 11	- Designing Compression Members (Columns).....	57
SECTION 12	- Designing for Shear .....	63
SECTION 13	- Combining Stresses for Unity Ratios .....	66
SECTION 14	- Designing Connections.....	68

# SECTION 1

## INTRODUCTION

The contents of this Design Manual is intended to give the structural engineer the tools with which he or she needs to safely and correctly design a fiberglass structure using pultruded fiberglass shapes.

When designing fiberglass structures, the attached Structural Design Basis (Section 3), should be followed as a minimum unless specifically required to follow a different set of design parameters. It should be noted that the following recommended design formulas and procedures are a compilation of input from different fiberglass pultrusion companies. AIMS International believes it has utilized the best, and most conservative of the available options. In addition to this design manual, AIMS has developed a 3-dimensional, structural analysis program which analyzes and designs specifically for fiberglass structural shapes, calculates deflections, stress, calculates unity ratios, and resizes members based upon the design parameters set forth in this manual.

The structural design engineer should be familiar with the concept of stress and deflection and the impact that one has on the other-----and the engineer should know that they are not interchangeable in fiberglass. It can typically be said that the sizing of fiberglass structural shapes is governed by deflection much more so than by stress, and that the converse is not true--- that stress governs more than deflection. It should always be the practice of the engineer to check both stress and deflection when designing fiberglass structures.

**If you have any questions or comments, please feel free to contact us toll free at 800-495-5997.**

---

## **SECTION 2**

### **THE BASICS OF FIBERGLASS PULTRUSION**

The contents of this Section are primarily a compilation of data from Creative Pultrusions, Inc. AIMS International, LLC has endeavored in this section to introduce to the users of this manual the basics of manufacturing fiberglass structural shapes.

Pultruded fiberglass structural shapes are manufactured by, and are available from several pultrusion companies, but there are three major suppliers that dominate the industry. It has been our experience that, among the three major suppliers, their products are very similar. The differences may be slightly differing moduli or strengths, but as long as the engineer keeps this in mind when performing the structural analysis, there should not be a negative side to inter-changing suppliers. However, Creative Pultrusions' Pultex<sup>®</sup> SuperStructurals have significantly higher material properties and the engineer must keep this in mind when performing the structural analysis. The use of SuperStructurals can be very cost effective as compared to designing with the standard structural shapes supplied by others.

The three most commonly used manufacturers of fiberglass pultruded structural shapes and their respective trade names are as follows:

Creative Pultrusions, Inc., Alum Bank, PA	Pultex <sup>®</sup>
Strongwell, Inc., Bristol, VA	Extren <sup>®</sup>
Bedford Reinforced Plastics, Inc., Bedford, PA	Bedford Shapes

There are several other companies that pultrude the smaller shapes used in the assembly of pultruded fiberglass gratings, but we are not talking about pultruded fiberglass gratings, we are talking about the larger fiberglass structural shapes, such as wide flange beams, I-beams, channels, angles, square and round tube, and other commonly used structural shapes. The above three manufacturers are the most advanced in their manufacturing and quality and, as a structural engineer, you would be well advised to specify and use one of the above three suppliers.

AIMS International, unless otherwise required to do so by customer requirement, uses solely the Creative Pultrusions' Pultex<sup>®</sup> line of structural shapes, however, we have no problems with using one of the other two, if requested to do so. This design specification incorporates, and is built around the Creative Pultrusions Pultex<sup>®</sup> product line as well as their resin and shape designations. All of the three suppliers have similar products and product designations, so interfacing and inter-changing between the three is very easy.

A pultruded fiberglass structural shape is comprised of reinforcing fibers and resin. In simple terms, the fiber reinforcement provides the structural stiffness, and the resin provides the resistance to the environment, be it ultra-violet resistance, chemical resistance, impact resistance, fire resistance, etc. Resins typically contain fillers to assist in achieving an intended performance characteristic.

Reinforcing fibers consist of continuous strand mat and continuous strand roving. Coupling the reinforcing fibers with the resin and a surfacing veil, the pultrusion product is complete. Typical structural shapes contain from 45% - 75% fiber reinforcement by weight.

A variety of continuous and woven reinforcement types are commonly used in fiberglass pultrusions. The four major types are E-Glass, S-Glass, aramid, and carbon. The most commonly used reinforcement is E-Glass. Other reinforcements are more costly, and therefore are used more sparingly in construction. The following Table 2-1 provides the physical properties of the four reinforcing fibers.

**Table 2-1 Typical Properties of Fibers Used in Pultruded Structural Profiles**

<b>Property</b>	<b>E-Glass</b>	<b>S-Glass</b>	<b>Aramid</b>	<b>Carbon</b>
Density lbs/in <sup>3</sup>	.094	.090	.053	.064
Tensile Strength (psi)	500,000	665,000	400,000	275,000 – 450,000
Tensile Modulus (10 <sup>6</sup> psi)	10.5	9.0	9.0	33 – 55
Elongation to break (%)	4.8	2.3	2.3	0.6 – 1.2

The following is a brief description of the reinforcing fibers:

**Continuous Strand Mat:** Long glass fibers intertwined and bound with a small amount of resin, called a binder. Continuous strand mat provides the most economical method of obtaining a high degree of transverse, or bi-directional strength characteristics. These mats are layered with roving, and this process forms the basic composition found in most pultruded products. The ratio of mat to roving determines the relationship of transverse to longitudinal strength characteristics.

**Continuous Strand Roving:** Each strand contains from 800-4,000 fiber filaments. Many strands are used in each pultrusion profile. This roving provides the high longitudinal strength of the pultruded product. The amount and location of these “rovings” can, and does alter the performance of the product. Roving also provides the tensile strength needed to pull the other reinforcements through the manufacturing die.

Since pultrusion is a low-pressure process, fiberglass reinforcements normally appear close to the surface of the product. This can affect appearance, corrosion resistance or handling of the products. Surface veils can be added to the laminate construction, and when used, displaces the reinforcement from the surface of the profile, creating a resin-rich surface. The two most commonly used veils are E-Glass and polyester.

Resin formulations typically consist of polyesters, vinyl esters, and epoxies, and are either fire retardant or non-fire retardant.

Polyesters and vinyl esters are the two primary resins used in the pultrusion process. Epoxy resins are typically used with carbon fiber reinforcements in applications where higher strength and stiffness characteristics are required. Epoxies can also be used with E-glass for improved physical properties.

The following Table 2-2 provides typical physical properties of resins used in pultruded structural shapes.

**Table 2-2 Typical Properties of Resins Used in Structural Pultrusions**

<b>Property</b>	<b>Polyester</b>	<b>Vinylester</b>	<b>Epoxy</b>	<b>Test Method</b>
Tensile Strength (psi)	11,200	11,800	11,000	ASTM D638
% Elongation	4.5	5	6.3	ASTM D638
Flexural Strength (psi)	17,800	20,000	16,700	ASTM D790
Flexural Modulus (10 <sup>6</sup> psi)	.43	0.54	0.47	ASTM D790
Heat Distortion Temperature (°F)	160	220	330	ASTM D648
Short Beam Shear (psi)	4,500	5,500	8,000	ASTM D2344

Various fillers are also used in the pultrusion process. Aluminum silicate (kaolin clay) is used for improved chemical resistance, opacity, good surface finish and improved insulation properties. Calcium carbonate offers improved surfaces, whiteness, opacity and general lowering of costs. Alumina trihydrate and antimony trioxide are used for fire retardancy. Alumina trihydrate can also be used to improve insulation properties.

Resin formulations in a pultruded fiberglass structural shape can be altered to achieve special characteristics as dictated by the environment in which the shape is intended for use. The most commonly used resins and trade names manufactured by Creative Pultrusions Inc. are:

**Pultex<sup>®</sup> Series 1500**, a non-fire retardant polyester resin, possesses good chemical resistance combined with high mechanical and electrical properties. This standard product is commonly used in moderately corrosive environments where fire resistance is not a concern.

**Pultex<sup>®</sup> Series 1525**, a fire retardant polyester resin, possess a flame spread rating of 25 or less as determined by the ASTM E-84 Tunnel Test, while maintaining the same characteristics as the 1500 Series. This product is commonly used in fire retardant structures commonly used offshore, such as wellhead access platforms, cable trays, etc., and it is commonly used onshore where fire resistance and moderate corrosion resistance are key elements in the design.

**Pultex<sup>®</sup> Series 1625** is a fire retardant vinyl ester resin which possesses excellent corrosion resistance, as well as better performance characteristics at elevated temperatures. This product should be used in highly corrosive environments and is a high performance standard structural. This material possesses an ASTM E-84 Tunnel Test flame spread rating of 25 or less.

**Pultex<sup>®</sup> Series 3535** is a modified polyester resin which possesses a low smoke generation characteristic, as well as a low flame spread rating, and is commonly used in the mass transit industry and in all applications where low smoke and low toxicity is of key importance.

When selecting the appropriate resin system to be incorporated into the pultruded product, the structural engineer should first refer to the Corrosion Guide in Section 8 of this document. Vinyl esters typically cost in the range of 10-15% more than polyester resins.

The structural engineer should also know that, because fiberglass is a plastic, it will undergo some decay and change of appearance due to prolonged exposure to outdoor weathering. In order to minimize this effect on fiberglass pultruded shapes, various options are available. Use of UV stabilizers and surfacing veils can be used, and coatings can also be applied to the structural shape. It should be noted that all Pultex<sup>®</sup> shapes contain UV stabilizers in the resin, and all shapes contain a surfacing veil as a standard.

UV stabilizers will retard the effect of weathering, but eventually the profile will degrade. A condition called “fiber blooming” will occur on the surface of the profile, and this is coupled with a slight reduction in physical properties.

Surfacing veils further enhance the profiles resistance to weathering. A synthetic veil, when applied to the surface of the fiberglass pultrusion during the manufacturing process, enhances weatherability and corrosion resistance by adding resin thickness to the surface of the product, i.e., it provides for a resin rich surface.

The optimum method of maintaining surface appearance during outdoor exposure is to apply a coating to the surface. Two-component, UV stabilized urethanes work very well with this application. A 1.5 mil dry film thickness coating will provide protection for many years with minimal change in appearance. This step, however, is non-standard for the Pultex<sup>®</sup> product line, and should be done by the fiberglass fabrication contractor in a controlled environment. AIMS typically does not paint its structures, however, we have painted handrails since they are typically the most visible component of a structure.



# **SECTION 3**

## **STRUCTURAL DESIGN BASIS**

The beams and girders of the a fiberglass structure should, as a minimum, be designed for the following basic load cases:

### Basic Load Cases

- BLC1. Dead load of structure.
- BLC2. Design live load as stipulated by the customer or by code.
- BLC3. Design storm wind @ El. (+) 33'-0" as stipulated by the customer or by code. The wind speed is a function of the elevation of the pertinent structure as related to the El. (+) 33'-0", and adjustments for the elevation should be made using the Wind Speed Evaluation per API RP 2A, 20<sup>th</sup> Edition, or by the appropriate governing code.
- BLC4. Design operating wind @ El. (+) 33'-0" as stipulated by the customer or by code, again with the same adjustments for elevation as discussed above.
- BLC5. If applicable, the forces resulting from the horizontal and vertical accelerations caused by a **100-yr storm** or hurricane on a floating vessel or as provided by the customer or by code (i.e., the movement resulting from a vessel on the high seas).
- BLC6. If applicable, the forces resulting from the horizontal & vertical accelerations caused by an **operating storm** on a floating vessel or as provided by the customer or by code (i.e., the movement resulting from a vessel on the high seas).
- BLC7. If applicable, the horizontal & vertical accelerations resulting from seismic activity as defined by code for the design location.

### Combined Load Cases

As a minimum, the combined load cases should be as follows:

#### **A. For filler beams or deck beams (not girders, columns, truss rows, or wind bracing):**

Operating Case:

$$(BLC1 \times 1.0) + (BLC2 \times 1.0) + (BLC4 \times 1.0) + (BLC6 \times 1.0) \quad \text{(if applicable)}$$

#### **B. For columns, girders, truss rows, and wind bracing:**

Operating Case (non-seismic):

$$(BLC1 \times 1.0) + (BLC2 \times 1.0^*) + (BLC4 \times 1.0) + (BLC6 \times 1.0) \quad \text{(if applicable)}$$

Storm Case (non-seismic):

$$(BLC1 \times 1.0) + (BLC2 \times 1.0^*) + (BLC3 \times 1.0) + (BLC5 \times 1.0) \quad \text{(if applicable)}$$

Operating Case (seismic):

$$(BLC1 \times 1.0) + (BLC2 \times 1.0^*) + (BLC4 \times 1.0) + (BLC7 \times 1.0)$$

\* see live load reduction below for additional information

The above design load combinations for the storm case assumes that the 100-yr storm will not occur at the same time as seismic activity. If the design premise set forth by the customer or code requires that they can occur simultaneously, then the engineer will be required to add (BLC7 x 1.0) to the load combinations.

Further, when applying wind loadings, the engineer must consider all of the critical wind directions and apply them to the structural model. As a minimum, the engineer should evaluate the winds in the X direction, the Y and an array of diagonal wind approach directions to create the worst load conditions on the particular member under evaluation.

#### Uniform Live Load vs. Actual Operating Equipment Loads

The uniform live load used above should be compared against the true and actual operating equipment loads to be applied to the structure (if this information is available). The engineer is to use whichever loading creates the worst loading on the structural elements under evaluation, either the true and actual operating equipment loads, or the uniform live loads. When using the actual operating equipment loads, **no live load reduction** (see below) is permitted.

#### Live Load Reduction

In this specification, the girders, trusses and columns beams are to be designed for the full dead load, and 100% of the uniform live load, unless the girder, truss row, or column supports an area greater than, or equal to, 100 square feet. If the supported area exceeds 100 square feet, a twenty (20%) percent Live Load Reduction (LLR) factor can be applied to the uniform live loading. This LLR is not applicable to dead loads, nor is it applicable to the actual equipment loads --- only the uniform live loads. **If the actual operating equipment loads are greater than the reduced live load (i.e., uniform live load x LLR), the engineer must not use uniform live loads in the analysis, but use only the actual operating equipment loads.**

Deck/Floor Live Loads: For any member supporting 100 square feet or more, be it a column, a girder, or a truss row, the design uniform live load applied to that member may be reduced by 20%, (i.e., multiplied by 0.80) if it meets the criteria set forth above.

Roof Live Loads: Use of a LLR for roof live loads is not permitted in any case.

### Snow Loading

The engineer is to consider snow loading, and all other environmental loadings in the structural analysis when applicable. The appropriate local design codes are to be adhered to.

### Impact and/or Dynamic Loading

The engineer is to consider impact loading on a case by case basis. When facing a design situation involving an impact or a dynamic loading situation, it is recommended that the structural designer increase the safety factors used in design by a magnitude of 2.0 (See Section 6).

### Concentrated Loads and Web Crippling

When designing beams which are subjected to concentrated loads, the structural engineer shall consider using web stiffeners to eliminate the effects of web crippling on the fiberglass pultruded shape. Stiffening can be achieved by bolting and/or epoxying angles, tees, or channels to the web of the beam being subjected to the concentrated loading. The analysis to determine the effectiveness is accomplished by treating the stiffening elements as a column, and designing in accordance with the criteria set forth in Section 11.

### One-third Increase in Allowable Stresses

A 1/3<sup>rd</sup> increase in allowable stress is permitted for all combined load cases involving storm winds or seismic activity. A 1/3<sup>rd</sup> increase in allowable stress is not permitted when evaluating combined loadings involving operating environmental conditions.

### Effects of Temperature

When designing fiberglass structures that will be subjected to high heat exposure, the engineer is cautioned to consider the effect of temperature as it relates to the allowable stresses and to the modulus of elasticity. The result of higher temperatures on structural fiberglass is a reduction in modulus of elasticity and thus, a lowering of the allowable stresses. These reductions in allowable stress and in modulus of elasticity are discussed in Section 7 of this document. Vinyl ester resins are better in elevated temperatures than polyester resins.

## Effects of Corrosion

Before the structural engineer begins any structural analysis, he or she should be knowledgeable as to the environment in which the structure is to be installed. The environment dictates the type of resin to be used, and the different resins possess different structural properties. In essence, the use of a polyester resin in designing a fiberglass structure will have lower allowable stresses and higher deflections than would the use of a vinyl ester resin in the same environment. Refer to Section 8 of this document for assistance in this matter.

## Deflections

As a minimum, all live load deflections of all beams and girders should be limited such that the deflection over length ratio ( $\Delta/L$ ) does not exceed 1/150. For cantilevered beams and girders, the deflection ratio should be limited to 1/100 ratio, or 1/4", whichever is greater.

The engineer is to be aware that, due to fiberglass' relatively low shear modulus, the total deflection of a fiberglass beam is actually comprised of two components:

- flexural deflection
- shear deflection

When calculating deflections of steel beams, due to steel's relatively high shear modulus, the shear deflection component is typically neglected. This is not the case in designing with fiberglass shapes. Refer to Section 9, Table 9-2 for the methodology in calculating the two components of the deflection. On average, the shear deflection will add an additional 10-15% to the deflection. The engineer is to use all standard and conventional methods for calculating deflections.

## **SECTION 4**

# **PHYSICAL PROPERTIES FOR DESIGNING WITH FIBERGLASS STRUCTURAL SHAPES**

Pultruded Fiberglass Structural Shapes distributed by AIMS International, LLC unless otherwise required by specification, are the Pultex<sup>®</sup> Pultrusion line of products manufactured by Creative Pultrusions, Inc. The following physical properties and tables are excerpts from the Pultex<sup>®</sup> Pultrusion Design Manual as prepared by Creative Pultrusions with corporate headquarters located at 214 Industrial Lane, P.O. Box 6, Alum Bank, Pennsylvania 15521. If the structural engineer plans to use the materials supplied by another pultrusion supplier, it is strongly recommended that he or she evaluates and compares the physical properties of the alternative materials and uses the appropriate values.

AIMS International, LLC and Creative Pultrusions, Inc. believe the information put forth in the following property sheets to be accurate and reliable as of the date of this publication. However, AIMS International, LLC and Creative Pultrusions, Inc. assume no obligation or liability which may arise as a result of its use. While AIMS International, LLC and Creative Pultrusions, Inc. have no knowledge that the information put forth infringes any valid patent, we assume no responsibility with respect thereto and each user must satisfy oneself that one's intended application process or product infringes no patent.

# Material Properties of Pultex<sup>®</sup> Fiber Reinforced Polymer Structural Profiles

## Rectangular Tubes, Channels, Angles, Square Tubes Angle profile sizes are 3" x 3" x 1/4" and less.

1500 Series- Thermoset Polyester- Olive Green  
 1525 Series- Thermoset Polyester Class 1 FR- Gray  
 1625 Series- Thermoset Vinyl Ester Class 1 FR- Beige

**The following data was derived from ASTM coupon and full section testing.** The results are average values based on random sampling and testing of production lots. Composite materials are not homogeneous, and therefore the location of the coupon extraction can cause variances in the coupon test results. Creative Pultrusions, Inc. publishes an average value of random samples from production lots.

Property (coupon values)	ASTM Test	Units	1500/1525 Series	1625 Series
<b>Mechanical</b>				
Tensile Strength (LW)	D638	psi	33,000	37,500
Tensile Strength (CW)	D638	psi	7,500	8,000
Tensile Modulus (LW)	D638	10 <sup>6</sup> psi	2.5	3.0
Tensile Modulus (CW)	D638	10 <sup>6</sup> psi	0.8	1.0
Compressive Strength (LW)	D695	psi	33,000	37,500
Compressive Strength (CW)	D695	psi	16,500	20,000
Compressive Modulus (LW)	D695	10 <sup>6</sup> psi	3.0	3.0
Compressive Modulus (CW)	D695	10 <sup>6</sup> psi	1.0	1.2
Flexural Strength (LW)	D790	psi	33,000	37,500
Flexural Strength (CW)	D790	psi	11,000	12,500
Flexural Modulus (LW)	D790	10 <sup>6</sup> psi	1.6	2.0
Flexural Modulus (CW)	D790	10 <sup>6</sup> psi	0.8	1.0
Modulus of Elasticity	Full Section <sup>2</sup>	10 <sup>6</sup> psi	2.8 – 3.2	2.8 – 3.2
(Channels)	Full Section <sup>2</sup>	10 <sup>6</sup> psi	2.8	2.8
(Square & Rectangular Tubes)	Full Section <sup>2</sup>	10 <sup>6</sup> psi	3.2	3.2
Shear Modulus	Full Section <sup>2</sup>	10 <sup>6</sup> psi	0.42	0.42
Short Beam Shear (LW)	D2344	psi	4,500	4,500
Shear Strength by Punch (PF)	D732	psi	5,500	6,000
Notched Izod Impact (LW)	D256	ft – lbs/in	28	30
Notched Izod Impact (CW)	D256	ft – lbs/in	4	5
Bearing Stress (LW)	D953	psi	30,000	30,000
Bearing Stress (CW)	D953	psi	18,000	18,000
Poisson's Ration (LW)	D3039	in/in	0.35	0.35
Poisson's Ration (CW)	D3039	in/in	0.15	0.15

LW = Lengthwise

CW = Crosswise

PF = Perpendicular to Laminate Face

(Continued next page)

# Material Properties of Pultex® Fiber Reinforced Polymer Structural Profiles

## Rectangular Tubes, Channels, Angles, Square Tubes *Angle profile sizes are 3" x 3" x 1/4" and less.* (continued)

Property (coupon values)	ASTM Test	Units	1500/1525 Series	1625 Series
<b>Physical</b>				
Barcol Hardness <sup>1</sup>	D2583		45	45
Water Absorption	D570	% Max	0.6	0.6
Density	D792	lbs/in <sup>3</sup>	0.060-0.070	0.060-0.070
Specific Gravity	D792		1.66-1.93	1.66-1.93
Coefficient of Thermal Expansion (LW)	D696	10 <sup>-6</sup> in/in/°F	4.4	4.4
Thermal Conductivity (PF)	C177	BTU- in/ft <sup>2</sup> /hr/°F	4	4
<b>Electrical</b>				
Arc Resistance (LW)	D495	seconds	120	120
Dielectric Strength (LW)	D149	KV/in	40	40
Dielectric Strength (PF)	D149	Volts/mil	200	200
Dielectric Constant (PF)	D150	@60Hz	5.2	5.2
Flammability Classification	UL94		(VO)	(VO)
Tunnel Test	ASTM E84		25 Max	25 Max
Flammability Extinguishing		Self	Self	
NBS Smoke Chamber	ASTM D635	Extinguishing	Extinguishing	
	ASTM E662		650	650
Flame Resistance (Ignition/Burn)	FTMS 406- 2023		55/30 (seconds)	55/30 (seconds)

<sup>1</sup> Pultex® uses a synthetic surface veil that reduces the Barcol hardness, but does not reflect lack of cure.

<sup>2</sup> Full section testing based on a 3-point bend with simply supported end conditions.



## Material Properties of Pultex<sup>®</sup> Fiber Reinforced Polymer Flat Sheets

1500 Series- Thermoset Polyester- Olive Green  
 1525 Series- Thermoset Polyester Class 1 FR- Gray  
 1625 Series- Thermoset Vinyl Ester Class 1 FR- Beige

**The following data was derived from ASTM coupon and full section testing.** The results are average values based on random sampling and testing of production lots. Composite materials are not homogeneous, and therefore the location of the coupon extraction can cause variances in the coupon test results. Creative Pultrusions, Inc. publishes an average value of random samples from production lots.

Property (coupon values)	ASTM Test	Units	1500/1525 Series	1625 Series
<b>Mechanical</b>				
Flexural Stress, Flatwise (LW)	D790	psi	35,000	35,000
Flexural Stress, Flatwise (CW)	D790	psi	15,000	15,000
Flexural Modulus, Flatwise (LW)	D790	10 <sup>6</sup> psi	2.0	2.0
Flexural Modulus, Flatwise (CW)	D790	10 <sup>6</sup> psi	1.1	1.1
Tensile Stress (LW)	D638	psi	20,000	20,000
Tensile Stress (CW)	D638	psi	10,000	10,000
Tensile Modulus (LW)	D638	10 <sup>6</sup> psi	1.8	1.8
Tensile Modulus (CW)	D638	10 <sup>6</sup> psi	1.0	1.0
Compressive Stress, Edgewise (LW)	D695	psi	24,000	24,000
Compressive Strength, Edgewise (CW)	D695	psi	16,000	16,000
Compressive Modulus, Edgewise (LW)	D695	10 <sup>6</sup> psi	1.8	1.8
Compressive Modulus, Edgewise (CW)	D695	10 <sup>6</sup> psi	1.0	1.0
Notched Izod Impact (LW)	D256	ft – lbs/in	20	20
Notched Izod Impact (CW)	D256	ft – lbs/in	5	5
Bearing Stress (LW)	D953	psi	32,000	32,000
Bearing Stress (CW)	D953	psi	32,000	32,000
Poisson's Ration (LW)	D3039		0.32	0.32
Poisson's Ration (CW)	D3039		0.25	0.25
<b>Physical</b>				
Barcol Hardness <sup>1</sup>	D2583		40	40
Water Absorption	D570	% Max	0.6	0.6
Density	D792	lbs/in <sup>3</sup>	0.060-0.070	0.060-0.070
Specific Gravity	D792		1.66-1.93	1.66-1.93
Coefficient of Thermal Expansion (LW)	D696	10 <sup>-6</sup> in/in/°F	8.0	8.0
<b>Electrical</b>				
Arc Resistance (LW)	D495	seconds	120	120
Dielectric Strength (LW)	D149	KV/in	40	40
Dielectric Strength (PF)	D149	Volts/mil	200	200
Dielectric Constant (PF)	D150	@60Hz	5.2	5.2

LW = Lengthwise                      CW = Crosswise                      PF = Perpendicular to Laminate Face

<sup>1</sup> Pultex<sup>®</sup> uses a synthetic surface veil that reduces the Barcol hardness, but does not reflect lack of cure.

## Material Properties of Pultex<sup>®</sup> Fiber Reinforced Polymer Rods & Bars

1500 Series- Thermoset Polyester- Olive Green  
 1525 Series- Thermoset Polyester Class 1 FR- Gray  
 1625 Series- Thermoset Vinyl Ester Class 1 FR- Beige

**The following data was derived from ASTM coupon and full section testing.** The results are average values based on random sampling and testing of production lots. Composite materials are not homogeneous, and therefore the location of the coupon extraction can cause variances in the coupon test results. Creative Pultrusions, Inc. publishes an average value of random samples from production lots.

Property (coupon values)	ASTM Test	Units	Test Results
<b>Mechanical</b>			
Tensile Strength (LW)	D638	psi	100,000
Tensile Modulus (LW)	D638	10 <sup>6</sup> psi	6.0
Compressive Strength (LW)	D695	psi	60,000
Flexural Strength (LW)	D790	psi	100,000
Flexural Modulus (LW)	D790	10 <sup>6</sup> psi	6.0
Notched Izod Impact (LW)	D256	ft – lbs/in	40
<b>Physical</b>			
Barcol Hardness	D2583		50
Water Absorption	D570	% Max	.25
Density	D792	lbs/in <sup>3</sup>	0.073-0.076
Coefficient of Thermal Expansion (LW)	D696	10 <sup>-6</sup> in/in/°F	3.0

LW = Lengthwise

## Material Properties of Superstud!<sup>TM</sup>/Nuts! Fiber Reinforced Polymer Fastener System

The following data was derived from ASTM coupon and full section testing. The results are average values based on random sampling and testing of production lots. Composite materials are not homogeneous, and therefore the location of the coupon extraction can cause variances in the coupon test results. Creative Pultrusions, Inc. publishes an average value of random samples from production lots.

Property (coupon values)	ASTM Test	Units	Diameter/Threads per Inch				
			3/8"	1/2"	5/8"	3/4"	1"
			16 UNC	13 UNC	11 UNC	10 UNC	8 UNC
Ultimate Thread Strength Using Standard C P Nut <sup>126</sup>		lbs	1,250	2,500	3,900	5,650	7,400
Max. Ultimate Design Tensile Load using C P Nut <sup>1256</sup>		lbs	1,000	2,000	3,120	4,520	6,200
Flexural Strength <sup>23</sup>	D790	psi	60,000	60,000	60,000	60,000	60,000
Flexural Modulus <sup>23</sup>	D790	10 <sup>6</sup> psi	2.0	2.0	2.0	2.5	2.75
Compressive Strength (LW) <sup>23</sup>	D695	psi	55,000	55,000	55,000	55,000	60,000
Ultimate Transverse Shear <sup>23</sup>	B565	load lb	4,200	7,400	11,600	17,200	27,400
Transverse Shear Yield <sup>23</sup>		load lb	2,100	3,300	4,500	7,500	12,500
Dielectric Strength <sup>23</sup>	D149	KV/in	40	40	40	40	40
Water Absorption <sup>2</sup>	D570	%	1	1	1	1	1
Coefficient of Thermal Expansion (LW)	D696	10 <sup>-6</sup> in/in/°F	3.0	3.0	3.0	3.0	3.0
Ultimate Torque Strength Using C P Full Nut Lubricated w/ SAE 10W30 Motor Oil <sup>2456</sup>		ft-lb	8	15	33	50	115
Stud Weight <sup>3</sup>		lb/ft	.076	.129	.209	.315	.592
Flammability			25	25	25	25	25

LW = Lengthwise

<sup>1</sup> Applies to single nut only; multiple nuts do not yield corresponding results.

<sup>2</sup> Ultimate strength values are averages obtained in design testing.

<sup>3</sup> Values are based on unthreaded rod.

<sup>4</sup> Torque results are dependant on several variable factors including the lubricant used, the length of the studs between nuts, alignment, washer surfaces, etc. Therefore, if such results of torque are important, it is vital that torque limits be determined experimentally for the exact installation conditions.

<sup>5</sup> Appropriate safety factors must be applied.

<sup>6</sup> Properties apply to Superstud!<sup>TM</sup> used with CP nut.

# Material Properties of Pultex<sup>®</sup> Fiber Reinforced Polymer SuperStructural Profiles

## Wide Flange Sections and I Sections

1500 Series- Thermoset Polyester- Olive Green  
 1525 Series- Thermoset Polyester Class 1 FR- Gray  
 1625 Series- Thermoset Vinyl Ester Class 1 FR- Beige

**The following data was derived from ASTM coupon and full section testing.** The results are average values based on random sampling and testing of production lots. Composite materials are not homogeneous, and therefore the location of the coupon extraction can cause variances in the coupon test results. Creative Pultrusions, Inc. publishes an average value of random samples from production lots.

Property (coupon values)	ASTM Test	Units	1500/1525 Series	1625 Series
<b>Full Section</b>				
Modulus of Elasticity (1/2" thick profiles)	Full Section <sup>2</sup>	10 <sup>6</sup> psi	3.9-4.0	3.9-4.0
(1/4" & 3/8" thick profiles)	Full Section <sup>2</sup>	10 <sup>6</sup> psi	3.9	3.9
Shear Modulus (Modulus of Rigidity)	Full Section <sup>2</sup>	10 <sup>6</sup> psi	4.0	4.0
Flexural Stress	Full Section <sup>2</sup>	psi	0.50	0.50
			33,000	33,000
<b>Flange Section Mechanical</b>				
Tensile Strength (LW)	D638	psi	40,000	46,000
Tensile Modulus (LW)	D638	10 <sup>6</sup> psi	4.16	4.16
Compressive Strength (LW)	D695	psi	45,770	52,500
Compressive Strength (CW)	D695	psi	17,800	20,400
Compressive Modulus (LW)	D695	10 <sup>6</sup> psi	3.85	3.85
Compressive Modulus (CW)	D695	10 <sup>6</sup> psi	1.9	1.9
Flexural Strength (LW)	D790	psi	42,800	49,200
Flexural Modulus (LW)	D790	10 <sup>6</sup> psi	2.0	2.0
Interlaminar Shear (LW)	D2344	psi	4,000	4,500
Shear Strength by Punch (PF)	D732	psi	5,500	6,000
Notched Izod Impact (LW)	D256	ft – lbs/in	28	32
Notched Izod Impact (CW)	D256	ft – lbs/in	21	24
Bearing Stress (LW)	D953	psi	33,000	38,000
Bearing Stress (CW)	D953	psi	23,000	26,500
Poisson's Ration (LW)	D3039	in/in	0.35	0.35
Poisson's Ration (CW)	D3039	in/in	0.12	0.12
<b>Web Section Mechanical</b>				
Tensile Strength (LW)	D638	psi	30,300	35,000
Tensile Strength (CW)	D638	psi	10,500	12,000
Tensile Modulus (LW)	D638	10 <sup>6</sup> psi	3.1	3.1
Tensile Modulus (CW)	D638	10 <sup>6</sup> psi	1.4	1.4
Compressive Strength (LW)	D695	psi	37,500	43,125
Compressive Strength (CW)	D695	psi	14,200	16,330
Compressive Modulus (LW)	D695	10 <sup>6</sup> psi	2.8	2.8
Compressive Modulus (CW)	D695	10 <sup>6</sup> psi	1.9	1.9
Flexural Strength (LW)	D790	psi	43,320	49,800

(Continued next page)

# Material Properties of Pultex<sup>®</sup> Fiber Reinforced Polymer SuperStructural Profiles

## Wide Flange Sections and I Sections (continued)

Property (coupon values)	ASTM Test	Units	1500/1525 Series	1625 Series
Flexural Strength (CW)	D790	psi	17,360	19,900
Flexural Modulus (LW)	D790	10 <sup>6</sup> psi	1.9	1.9
Flexural Modulus (CW)	D790	10 <sup>6</sup> psi	1.75	1.75
Interlaminar Shear (LW)	D2344	psi	3,400	3,900
Shear Strength by Punch (PF)	D732	psi	5,500	6,000
Notched Izod Impact (LW)	D256	ft – lbs/in	38	43
Notched Izod Impact (CW)	D256	ft – lbs/in	19	22
Bearing Stress (LW)	D953	psi	33,980	39,000
Bearing Stress (CW)	D953	psi	30,000 <sup>3</sup>	34,500
Poisson's Ration (LW)	D3039	in/in	0.35	0.35
Poisson's Ration (CW)	D3039	in/in	0.12	0.12
In-plane Shear (CW)	modified D2344 <sup>4</sup>	psi	7,000	7,000
In-plane Shear (LW)	modified D2344 <sup>4</sup>	psi	4,500	4,500
<b>Physical</b>				
Barcol Hardness <sup>1</sup>	D2583		33	39
Water Absorption	D570	% Max	0.6	0.6
Density	D792	lbs/in <sup>3</sup>	0.060-0.070	0.060-0.070
Specific Gravity	D792		1.66-1.93	1.66-1.93
Coefficient of Thermal Expansion (LW)	D696	10 <sup>-6</sup> in/in/°F	4.4	4.4
Thermal Conductivity (PF)	C177	BTU- in/ft <sup>2</sup> /hr/°F	4	4
<b>Electrical</b>				
Arc Resistance (LW)	D495	seconds	120	120
Dielectric Strength (LW)	D149	KV/in	40	40
Dielectric Strength (PF)	D149	Volts/mil	200	200
Dielectric Constant (PF)	D150	@60Hz	5.2	5.2

LW = Lengthwise      CW = Crosswise      PF = Perpendicular to Laminate Face

<sup>1</sup> Pultex<sup>®</sup> uses a synthetic surface veil that reduces the Barcol hardness, but does not reflect lack of cure.

<sup>2</sup> Full section testing based on a 3-point bend with simply supported end conditions.

<sup>3</sup> Crosswise bearing stress of Web sections of ¼" profiles = 20,500 psi

<sup>4</sup> Follow ASTM D2344, but rotate coupon 90 deg. (cut section of coupon length faces up)

Property	ASTM Test	1500/1525 Series	1625 Series
Flammability Classification	UL94	(VO)	(VO)
Tunnel Test	ASTM E84	25 Max	25 Max
Flammability Extinguishing	ASTM D635	Self Extinguishing	Self Extinguishing
NBS Smoke Chamber	ASTM E662	650	650
Flame Resistance (Ignition/Burn)	FTMS 406-2023	55/30 (seconds)	55/30 (seconds)

# Material Properties of Pultex<sup>®</sup> Fiber Reinforced Polymer SuperStructural Profiles

## Angles

*Angle profile sizes are 4" x 4" x 1/4" and larger.*

1500 Series- Thermoset Polyester- Olive Green  
 1525 Series- Thermoset Polyester Class 1 FR- Gray  
 1625 Series- Thermoset Vinyl Ester Class 1 FR- Beige

**The following data was derived from ASTM coupon and full section testing.** The results are average values based on random sampling and testing of production lots. Composite materials are not homogeneous, and therefore the location of the coupon extraction can cause variances in the coupon test results. Creative Pultrusions, Inc. publishes an average value of random samples from production lots.

Property (coupon values)	ASTM Test	Units	1500/1525 Series	1625 Series
<b>Mechanical</b>				
Tensile Strength (LW)	D638	psi	31,000	35,600
Tensile Strength (CW)	D638	psi	16,500	18,900
Tensile Modulus (LW)	D638	10 <sup>6</sup> psi	3.5	3.5
Tensile Modulus (CW)	D638	10 <sup>6</sup> psi	1.0	1.0
Compressive Strength (LW)	D695	psi	33,800	44,500
Compressive Strength (CW)	D695	psi	25,500	29,000
Compressive Modulus (LW)	D695	10 <sup>6</sup> psi	3.0	3.0
Compressive Modulus (CW)	D695	10 <sup>6</sup> psi	2.2	2.2
Flexural Strength (LW)	D790	psi	43,500	50,000
Flexural Strength (CW)	D790	psi	24,000	27,500
Flexural Modulus (LW)	D790	10 <sup>6</sup> psi	1.9	1.9
Flexural Modulus (CW)	D790	10 <sup>6</sup> psi	1.6	1.6
Modulus of Elasticity	Full Section <sup>2</sup>	10 <sup>6</sup> psi	2.8	2.8
Shear Modulus	Full Section <sup>2</sup>	10 <sup>6</sup> psi	0.5	0.5
Interlaminar Shear (LW)	D2344	psi	3,400	3,900
Shear Strength by Punch (PF)	D732	psi	5,500	6,000
Notched Izod Impact (LW)	D256	ft – lbs/in	34	39
Notched Izod Impact (CW)	D256	ft – lbs/in	33	38
Bearing Stress (LW)	D953	psi	33,000	38,000
Bearing Stress (CW)	D953	psi	33,000	38,000
Poisson's Ration (LW)	D3039	in/in	0.35	0.35
Poisson's Ration (CW)	D3039	in/in	0.12	0.12
In-plane Shear (LW)	modified	D2344	psi	4,500
In-plane Shear (CW)	modified	D2344	psi	7,000

(Continued next page)

## Material Properties of Pultex<sup>®</sup> Fiber Reinforced Polymer SuperStructural Profiles

### Angles

*Angle profile sizes are 4" x 4" x 1/4" and larger.*

(continued)

Property (coupon values)	ASTM Test	Units	1500/1525 Series	1625 Series
<b>Physical</b>				
Barcol Hardness <sup>1</sup>	D2583		45	45
Water Absorption	D570	% Max	0.6	0.6
Density	D792	lbs/in <sup>3</sup>	0.060-0.070	0.060-0.070
Specific Gravity	D792		1.66-1.93	1.66-1.93
Coefficient of Thermal Expansion (LW)	D696	10 <sup>-6</sup> in/in/°F	4.4	4.4
Thermal Conductivity (PF)	C177	BTU- in/ft <sup>2</sup> /hr/°F	4	4
<b>Electrical</b>				
Arc Resistance (LW)	D495	seconds	120	120
Dielectric Strength (LW)	D149	KV/in	40	40
Dielectric Strength (PF)	D149	Volts/mil	200	200
Dielectric Constant (PF)	D150	@60Hz	5.2	5.2

LW = Lengthwise

CW = Crosswise

PF = Perpendicular to Laminate Face

<sup>1</sup> Pultex<sup>®</sup> uses a synthetic surface veil that reduces the Barcol hardness, but does not reflect lack of cure.

<sup>2</sup> Full section testing based on a 3-point bend with simply supported end conditions.

<sup>3</sup> Follow ASTM D2344, but rotate coupon 90 deg. (cut section of coupon length faces up)

Property	ASTM Test	1500/1525 Series	1625 Series
Flammability Classification	UL94	(VO)	(VO)
Tunnel Test	ASTM E84	25 Max	25 Max
Flammability Extinguishing	ASTM D635	Self Extinguishing	Self Extinguishing
NBS Smoke Chamber	ASTM E662	650	650
Flame Resistance (Ignition/Burn)	FTMS 406-2023	55/30 (seconds)	55/30 (seconds)

## **SECTION 5**

### **CROSS SECTIONAL AND ENGINEERING PROPERTIES OF FIBERGLASS STRUCTURAL SHAPES**



## Wide Flange Sections

Depth (h)	Width (b)	Thickness (t)	Area	Weight	X-X Axis			Y-Y Axis			Design	
					I	S	r	I	S	r	J	C <sub>w</sub>
in	in	in	in <sup>2</sup>	lb/ft	in <sup>4</sup>	in <sup>3</sup>	in	in <sup>4</sup>	in <sup>3</sup>	in	in <sup>4</sup>	in <sup>6</sup>
3.00	3.00	0.25	2.17	1.63	3.23	2.15	1.22	1.11	0.74	0.71	0.047	2.49
4.00	4.00	0.25	2.92	2.19	8.05	4.03	1.66	2.63	1.32	0.95	0.063	10.52
6.00	6.00	0.25	4.42	3.31	28.58	9.53	2.54	8.91	4.46	1.42	0.094	80.21
6.00	6.00	0.375	6.57	4.92	40.76	13.59	2.49	13.32	4.44	1.42	0.316	119.84
8.00	8.00	0.375	8.82	6.61	100.35	25.09	3.37	31.65	7.91	1.90	0.422	506.46
8.00	8.00	0.50	11.67	8.75	128.81	32.20	3.32	42.09	10.52	1.90	1.000	673.41
10.00	10.00	0.375	11.07	8.30	200.45	40.09	4.26	61.94	12.39	2.37	0.527	1548.59
10.00	10.00	0.50	14.67	11.00	259.36	51.87	4.20	82.38	16.48	2.37	1.250	2059.52
12.00	12.00	0.50	17.67	13.25	457.26	76.21	5.09	142.59	23.77	2.84	1.500	5133.35

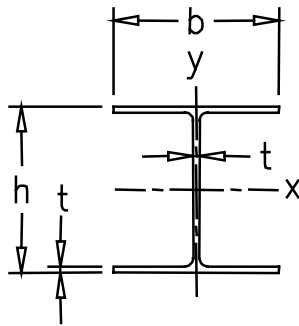

## I Sections

Depth (h)	Width (b)	Thickness (t)	Area	Weight	X-X Axis			Y-Y Axis			Design	
					I	S	r	I	S	r	J	C <sub>w</sub>
in	in	in	in <sup>2</sup>	lb/ft	in <sup>4</sup>	in <sup>3</sup>	in	in <sup>4</sup>	in <sup>3</sup>	in	in <sup>4</sup>	in <sup>6</sup>
3.00	1.50	0.25	1.42	1.06	1.80	1.20	1.18	0.14	0.19	0.31	0.031	0.31
4.00	2.00	0.25	1.92	1.44	4.53	2.27	1.54	0.33	0.33	0.41	0.042	1.32
6.00	3.00	0.25	2.92	2.19	16.17	5.39	2.35	1.11	0.74	0.62	0.063	9.99
6.00	3.00	0.375	4.32	3.24	22.93	7.64	2.31	1.67	1.11	0.62	0.211	15.00
8.00	4.00	0.375	5.82	4.36	56.71	14.18	3.12	3.95	1.97	0.82	0.281	63.12
8.00	4.00	0.50	7.67	5.75	72.48	18.12	3.07	5.27	2.63	0.82	0.667	84.26
10.00	5.00	0.375	7.32	5.49	113.55	22.71	3.94	7.71	3.08	1.03	0.352	192.80
10.00	5.00	0.50	9.67	7.25	146.45	29.29	3.89	10.27	4.11	1.03	0.833	256.84
12.00	6.00	0.50	11.67	8.75	258.76	43.13	4.71	17.76	5.92	1.23	1.000	639.33

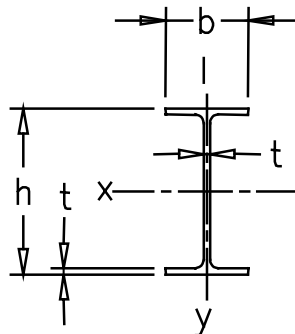

## Equal Leg Angles

Depth (h) in	Width (b) in	Thickness (t) in	Area in <sup>2</sup>	Weight lbs/ft	X-X Axis or Y-Y Axis			
					I in <sup>4</sup>	S in <sup>3</sup>	r <sub>x,y</sub> in	r <sub>z</sub> in
1.00	1.00	0.125	0.22	0.170	0.02	0.03	0.30	0.182
1.00	1.00	0.250	0.42	0.320	0.03	0.05	0.29	0.183
1.125	1.125	0.125	0.25	0.190	0.03	0.04	0.34	0.207
1.50	1.50	0.125	0.35	0.260	0.08	0.07	0.47	0.284
1.50	1.50	0.1875	0.51	0.390	0.11	0.10	0.45	0.282
1.50	1.50	0.250	0.67	0.500	0.13	0.13	0.45	0.281
2.00	2.00	0.125	0.47	0.350	0.19	0.13	0.63	0.386
2.00	2.00	0.1875	0.70	0.530	0.27	0.19	0.62	0.383
2.00	2.00	0.250	0.92	0.690	0.34	0.24	0.61	0.381
3.00	3.00	0.125	0.72	0.540	0.65	0.30	0.95	0.590
3.00	3.00	0.1875	1.08	0.810	0.95	0.44	0.94	0.587
3.00	3.00	0.250	1.42	1.070	1.22	0.57	0.93	0.584
3.00	3.00	0.375	2.09	1.570	1.72	0.82	0.91	0.578
4.00	4.00	0.250	1.92	1.440	3.00	1.03	1.25	0.787
4.00	4.00	0.375	2.84	2.130	4.29	1.50	1.23	0.780
4.00	4.00	0.500	3.72	2.790	5.45	1.93	1.21	0.774
6.00	6.00	0.250	2.92	2.190	10.49	2.38	1.89	1.194
6.00	6.00	0.375	4.34	3.250	15.23	3.49	1.87	1.185
6.00	6.00	0.500	5.72	4.290	19.65	4.55	1.85	1.177

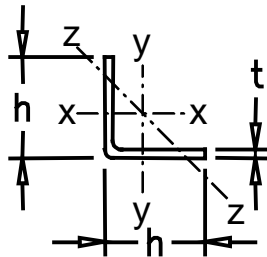

## Unequal Leg Angles

Depth (h)  in	Width (b)  in	Thickness (t)  in	Area  in <sup>2</sup>	Weight  lbs/ft	X-X Axis			Y-Y Axis		
					I in <sup>4</sup>	S in <sup>3</sup>	R in	I in <sup>4</sup>	S in <sup>3</sup>	R in
1.25	0.75	0.125	0.22	0.17	0.03	0.04	0.39	0.01	0.02	0.21
1.50	1.00	0.125	0.29	0.23	0.07	0.07	0.48	0.02	0.03	0.29
2.00	1.00	0.125	0.35	0.26	0.14	0.11	0.64	0.03	0.03	0.27
2.00	1.00	0.1875	0.51	0.39	0.21	0.16	0.63	0.04	0.05	0.26
2.00	1.00	0.25	0.67	0.5	0.26	0.21	0.62	0.04	0.060	0.25
2.00	1.25	0.250	0.73	0.55	0.29	0.22	0.62	0.09	0.090	0.34
2.00	1.50	0.125	0.41	0.31	0.17	0.12	0.64	0.08	0.07	0.45
2.00	1.50	0.25	0.80	0.60	0.31	0.23	0.62	0.15	0.14	0.43
2.25	1.50	0.1875	0.65	0.49	0.33	0.22	0.71	0.12	0.11	0.43
2.63	1.63	0.125	0.50	0.38	0.37	0.21	0.85	0.11	0.09	0.47
3.00	1.00	0.125	0.47	0.35	0.44	0.24	0.96	0.03	0.03	0.24
3.00	1.50	0.125	0.54	0.40	0.51	0.26	0.98	0.09	0.08	0.41
3.00	1.50	0.1875	0.80	0.60	0.74	0.39	0.97	0.13	0.11	0.40
3.00	1.50	0.250	1.05	0.79	0.96	0.50	0.96	0.16	0.14	0.40
3.00	2.00	0.1875	0.89	0.67	0.83	0.41	0.96	0.30	0.20	0.58
3.00	2.00	0.250	1.17	0.91	1.06	0.53	0.95	0.38	0.26	0.57
3.00	2.00	0.375	1.71	1.28	1.49	0.76	0.93	0.53	0.36	0.55
4.00	2.00	0.250	1.42	1.07	2.36	0.92	1.29	0.41	0.26	0.54
4.00	2.00	0.375	2.09	1.57	3.36	1.33	1.27	0.57	0.37	0.52
4.00	3.00	0.250	1.67	1.25	2.73	0.99	1.28	1.33	0.59	0.89
4.00	3.00	0.375	2.46	1.85	3.89	1.43	1.26	1.88	0.85	0.87
5.00	3.50	0.50	3.97	2.98	9.81	2.93	1.57	3.96	1.53	1.00
6.00	4.00	0.250	2.42	1.82	9.18	2.24	1.95	0.38	1.09	1.18
6.00	4.00	0.375	3.59	2.69	13.31	3.28	1.93	4.83	1.58	1.16
6.00	4.00	0.500	4.72	3.54	17.15	4.27	1.91	6.16	2.04	1.14
11.00	3.50	0.125	1.79	1.39	23.19	3.43	3.60	1.38	0.46	0.88

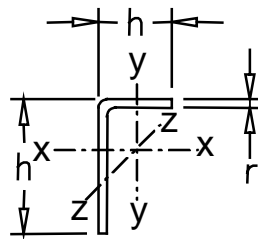

## Channels

Depth (h) in	Width (b) in	Thickness (t) in	Area in <sup>2</sup>	Weight lbs/ft	X-X Axis			Y-Y Axis		
					I in <sup>4</sup>	S in <sup>3</sup>	r in	I in <sup>4</sup>	S in <sup>3</sup>	r in
1.50	1.00	0.1875	0.55	0.41	0.17	0.22	0.55	0.05	0.08	0.30
1.23	1.50	0.100	0.39	0.29	0.10	0.16	0.51	0.09	0.10	0.48
2.00	0.56	0.125	0.34	0.260	0.16	0.16	0.69	0.01	0.02	0.15
2.31	1.00	0.160	0.60	0.45	0.43	0.38	0.85	0.05	0.07	0.29
2.50	0.75	0.0937	0.34	0.26	0.27	0.22	0.90	0.02	0.030	0.21
2.63	1.00	0.016	0.65	0.48	0.59	0.45	0.96	0.05	0.070	0.29
2.75	1.00	0.125	0.56	0.42	0.59	0.43	1.02	0.05	0.06	0.29
3.00	0.875	0.250	1.00	0.75	1.02	0.68	1.01	0.05	0.08	0.22
3.00	1.00	0.1875	0.83	0.62	0.95	0.63	1.07	0.06	0.09	0.27
3.00	1.50	0.250	1.310	0.98	1.61	1.07	1.11	0.25	0.25	0.44
4.00	1.06	0.125	0.71	0.53	1.46	0.73	1.43	0.06	0.07	0.29
4.00	1.13	0.250	1.37	1.03	2.62	1.31	1.38	0.12	0.14	0.29
4.00	1.75	0.1875	1.34	1.00	3.13	1.56	1.53	0.36	0.28	0.52
5.00	1.38	0.250	1.75	1.31	5.42	2.17	1.76	0.24	0.23	0.37
6.00	1.63	0.250	2.12	1.59	9.62	3.21	2.13	0.40	0.32	0.44
6.00	1.69	0.375	3.10	2.33	13.43	4.48	2.08	0.62	0.50	0.45
7.00	2.00	0.250	2.57	1.92	16.42	4.69	2.53	0.79	0.50	0.56
8.00	2.19	0.250	2.91	2.18	24.30	6.08	2.89	1.07	0.63	0.61
8.00	2.19	0.375	4.23	3.17	33.75	8.44	2.83	1.47	0.89	0.59
10.00	2.25	0.100	1.41	1.06	18.48	3.70	3.61	0.54	0.29	0.62
10.00	2.75	0.125	1.88	1.41	25.88	5.18	3.71	1.18	0.53	0.79
10.00	2.75	0.500	7.01	5.26	86.88	17.38	3.52	3.83	1.86	0.74
11.50	2.75	0.500	7.78	5.84	124.58	21.67	4.00	4.05	1.93	0.72
24.00	3.00	0.250	7.33	5.50	475.40	39.62	8.05	3.37	1.30	0.68
24.00	4.00	0.470	14.52	10.89	985.09	82.09	8.24	13.71	4.14	0.97

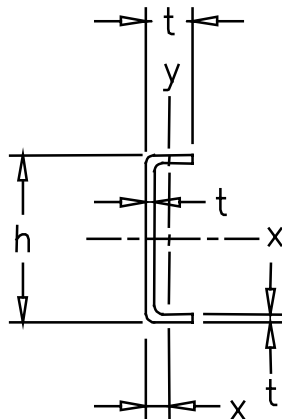

## Square Tubes

Width or Depth (h) in	Thickness (t) in	Area in <sup>2</sup>	Weight lbs/ft	X-X Axis or Y-Y Axis		
				I in <sup>4</sup>	S in <sup>3</sup>	r in
1.00	0.125	0.42	0.32	0.05	0.11	0.36
1.25	0.250	0.93	0.69	0.16	0.26	0.42
1.50	0.125	0.67	0.51	0.21	0.28	0.56
1.50	0.250	1.24	0.93	0.33	0.44	0.52
1.75	0.1250	0.80	0.60	0.35	0.40	0.66
1.75	0.250	1.48	1.11	0.57	0.67	0.62
2.00	0.125	0.92	0.69	0.53	0.53	0.76
2.00	0.250	1.73	1.30	0.89	0.89	0.72
2.11	0.200	1.48	1.11	0.91	0.86	0.78
2.50	0.250	2.24	1.68	1.90	1.52	0.92
3.00	0.250	2.74	2.05	3.47	2.31	1.13
4.00	0.250	3.73	2.80	8.75	4.37	1.53

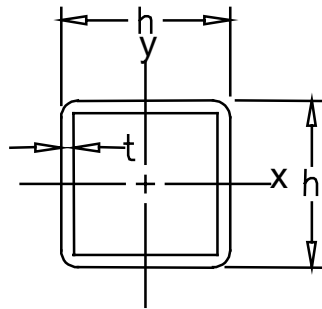

## Rectangular Tubes

Depth (h)	Width (b)	Thickness (t)	Area	Weight	X - X Axis			X - X Axis		
					I	S	r	I	S	r
in	in	in	in <sup>2</sup>	lb/ft	in <sup>4</sup>	in <sup>3</sup>	in	in <sup>4</sup>	in <sup>3</sup>	in
4.40	1.43	0.125	1.38	1.03	2.89	1.31	1.45	0.49	0.68	0.59
4.74	1.72	0.125	1.57	1.17	4.20	1.77	1.64	0.79	0.91	0.71
5.00	0.75	0.125	1.37	1.03	3.15	1.26	1.52	0.11	0.31	0.28
5.07	2.00	0.132	1.80	1.35	5.65	2.23	1.77	1.23	1.23	0.83
6.00	2.00	0.125	2.39	1.79	9.34	3.11	1.98	1.61	1.61	0.82
6.00	4.00	0.250	4.62	3.46	22.31	7.44	2.20	11.84	5.92	1.61
7.00	4.00	0.250	5.20	3.90	33.61	9.61	2.54	13.91	6.95	1.64
7.00	4.00	0.375	7.63	5.73	47.58	13.60	2.50	19.25	9.63	1.59
7.30	1.27	0.190	3.02	2.26	15.37	4.21	2.26	0.80	1.26	0.51
7.750	1.75	0.188	3.38	2.53	20.86	5.38	2.49	1.82	2.08	0.73
8.00	1.00	0.125	2.45	1.84	14.14	3.54	2.40	0.40	0.81	0.41
8.00	1.00	0.250	4.39	3.30	24.62	6.16	2.37	0.58	1.16	0.36
8.00	4.00	0.250	5.70	4.27	46.80	11.70	2.87	15.67	7.83	1.66
8.00	4.00	0.375	8.38	6.29	66.63	16.66	2.82	21.73	10.86	1.61

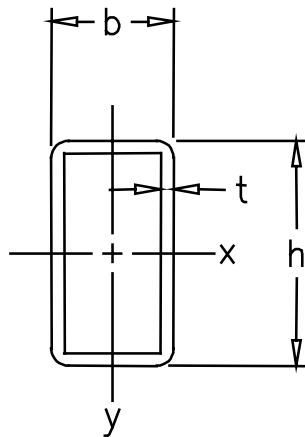

## Round Tubes

Outside Diameter (OD)	Inside Diameter (ID)	Thickness (t)	Area	Weight	X-X Axis or Y-Y Axis		
					I	S	r
in	in	in	in <sup>2</sup>	lbs/ft	in <sup>4</sup>	in <sup>3</sup>	in
0.75	0.56	0.0937	0.19	0.14	0.01	0.03	0.23
1.00	0.75	0.125	0.34	0.26	0.03	0.07	0.31
1.25	0.88	0.1875	0.63	0.47	0.09	0.15	0.38
1.25	1.00	0.125	0.44	0.33	0.07	0.11	0.40
1.25	1.00	0.0937	0.34	0.26	0.06	0.09	0.41
1.50	1.00	0.250	0.98	0.74	0.20	0.27	0.45
1.50	1.25	0.125	0.54	0.41	0.13	0.17	0.49
1.75	1.25	0.250	1.18	0.88	0.34	0.39	0.54
1.75	1.50	0.125	0.64	0.48	0.21	0.24	0.58
2.00	1.50	0.250	1.37	1.03	0.54	0.54	0.63
2.00	1.75	0.125	0.73	0.63	0.33	0.33	0.66
2.50	2.00	0.250	1.77	1.33	1.13	0.91	0.80
2.50	2.25	0.125	0.93	0.70	0.66	0.53	0.84
3.00	2.50	0.250	2.16	1.62	2.06	1.37	0.98
3.50	2.94	0.280	2.84	2.13	3.71	2.12	1.14

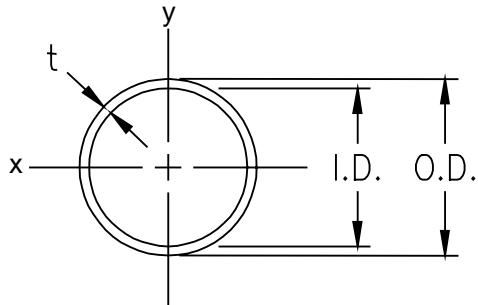



## Solid Round Tubes

Diameter (d)	Area	Weight	X-X Axis or Y-Y Axis		
			I	S	r
in	in <sup>2</sup>	lbs/ft	in <sup>4</sup>	in <sup>3</sup>	in
0.125	0.010	0.008	<0.001	<0.001	0.031
0.1875	0.028	0.021	<0.001	0.0010	0.047
0.250	0.049	0.037	<0.001	0.0020	0.063
0.3125	0.077	0.058	<0.001	0.003	0.078
0.375	0.110	0.083	0.001	0.005	0.094
0.500	0.196	0.147	0.003	0.012	0.125
0.625	0.307	0.230	0.008	0.024	0.156
0.750	0.442	0.331	0.016	0.041	0.188
0.8125	0.519	0.389	0.021	0.053	0.203
0.875	0.601	0.451	0.029	0.066	0.219
1.000	0.785	0.589	0.049	0.098	0.250
1.250	1.227	0.920	0.120	0.192	0.313
1.500	1.767	1.325	0.249	0.331	0.375
2.000	3.142	2.356	0.785	0.785	0.500
2.500	4.909	3.682	1.918	1.534	0.625

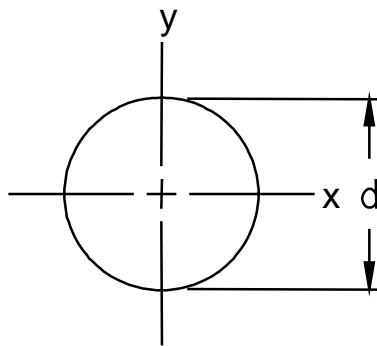

## Solid Bars

Depth (h)	Width (b)	Area	Weight	X-X Axis			Y-Y Axis		
				I	S	r	I	S	r
in	in	in <sup>2</sup>	lbs/ft	in <sup>4</sup>	in <sup>3</sup>	in	in <sup>4</sup>	in <sup>3</sup>	in
0.25	0.25	0.06	0.05	<0.001	0.002	0.07	<0.001	0.002	0.07
1.00	0.50	0.50	0.37	0.04	0.08	0.29	0.01	0.04	0.14
1.25	0.75	0.93	0.70	0.12	0.19	0.36	0.04	0.12	0.22
1.00	1.00	0.99	0.74	0.08	0.16	0.29	0.08	0.16	0.29
1.23	1.23	1.51	1.13	0.19	0.31	0.35	0.19	0.31	0.35
1.50	1.50	2.25	1.69	0.42	1.36	0.43	0.42	1.36	0.43
1.46	1.46	2.12	1.59	0.37	0.51	0.42	0.37	0.51	0.42
2.00	2.00	3.98	2.98	1.31	1.31	0.57	1.31	1.31	0.57

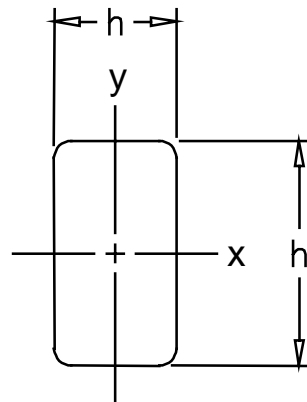

## **SECTION 6**

### **SAFETY FACTORS USED IN DESIGNING WITH FIBERGLASS SHAPES**

Safety factors are defined as the ratio of the ultimate stress to the allowable stress.

$$\text{Safety Factor (S.F.)} = \text{Ultimate Stress (U.S.)} / \text{Allowable Stress (A.S.)}$$

$$\text{Therefore, A.S.} = \text{U.S.} / \text{S.F.}$$

Safety factors compensate for:

- allowable tolerances of the part
- uncertainty of the anticipated loading (magnitude, type or placement)
- assumptions in methods of analysis
- fabrication tolerances (squareness of cuts, normal tolerances, etc.)

The safety factors used in the various design equations were chosen to prevent “first deformation” of the part. First deformation is defined as the first visible deformation including local flange or web buckling, twisting, crushing, etc. The recommended safety factors used for design are:

LOADING TYPE	RECOMMENDED SAFETY FACTORS
Flexural members, beams	2.5
Compression members, columns	3.0
Tension members	4.0
Beam shear	3.0
Connections	4.0

MODULI	RECOMMENDED SAFETY FACTORS
Modulus of Elasticity	1.0
Shear Modulus	1.0

NOTES:

1. The safety factors given are for **static load conditions only**. Safety factors for impact loads and dynamic loads are typically **two times** the static load safety factor. Long term service loads which result in creep deformations will require even higher safety factors to insure satisfactory performance. For creep effects, see *Structural Plastics Design Manual*, American Society of Civil Engineers, 345 East 47<sup>th</sup> Street, New York, NY 10017, Vols. 1 and 2, September 1981.

These recommended safety factors are not the only safety factors that may be used in design. The designer may choose to adjust the safety factors based on particular applications and considerations including margin of safety, costs, confidence of loads or materials, etc.

**Ultimately, the final selection of a safety factor is the designer’s privilege as well as responsibility.**

## **SECTION 7**

### **EFFECTS OF TEMPERATURE ON FIBERGLASS STRUCTURAL SHAPES**

Pultruded structural shapes experience some loss of structural integrity from continuous exposure to elevated temperatures, and therefore, it is strongly recommended that this effect be considered when performing a structural design with fiberglass pultrusions. Table 7-1 provides the retention of ultimate stress for the Pultex<sup>®</sup> products resulting from exposure to elevated temperatures while Table 7-2 provides the retention of modulus of elasticity:

**Table 7-1 Ultimate Stress Retention at Varying Temperatures**

Temperature	Pultex <sup>®</sup> 1500/1525 Series	Pultex <sup>®</sup> 1625 Series
100°	85%	90%
125°	70%	80%
150°	50%	80%
175°	Not Recommended	75%
200°	Not Recommended	50%

**Table 7-2 Retention of Modulus of Elasticity at Varying Temperatures**

Temperature	Pultex <sup>®</sup> 1500/1525 Series	Pultex <sup>®</sup> 1625 Series
100°	100%	100%
125°	90%	95%
150°	85%	90%
175°	Not Recommended	88%
200°	Not Recommended	85%

In applications requiring greater strength retention, it is possible to select a higher performance resin system specifically designed for elevated temperatures. An example is Pultex<sup>®</sup> 1625 Series Vinyl Ester, which has better strength retention at elevated temperatures. Additional resin systems can be design by Creative Pultrusions, Inc. to achieve even higher temperature ratings, if required.

## **SECTION 8**

### **CORROSION GUIDE FOR THE PROPER SELECTION OF RESINS**

# Chemical Compatibility Guide

## Acetic Acid – Benzene

Pultex® Structural Profiles  
 1500/1525 Srs.      1625 Srs.  
 Temp. Max      Temp. Max

Chemical Environment	Concentration Percentage	Temp. Max F/C	Temp. Max F/C
ACETIC ACID	0-50	NR	100/38
ACETIC ANYDRIDE	--	NR	NR
ACETONE	100	NR	NR
ACRYLONITRILE	100	NR	NR
ALCOHOL, BUTYL	--	NR	NR
ALCOHOL, ETHYL	10	NR	150/65
ALCOHOL, ETHYL	100	NR	NR
ALCOHOL, ISOPROPYL	10	NR	150/65
ALCOHOL, ISOPROPYL	100	NR	NR
ALCOHOL, METHYL	10	NR	150/65
ALCOHOL, METHYL	100	NR	NR
ALCOHOL, METHYL ISOBUTYL	--	NR	150/65
ALCOHOL, SECONDARY BUTYL	--	NR	150/65
ALUM	100	150/65	150/65
ALUM POTASSIUM	--	100/38	100/38
ALUMINUM CHLORIDE	10	NR	150/65
ALUMINUM HYDROXIDE	5 – 20	NR	150/65
ALUMINUM POTASSIUM SULFATE	100	150/65	150/65
AMMONIA, AQUEOUS	0 - 10	NR	100/38
AMMONIA, GAS	--	NR	100/38
AMMONIUM ACETATE	25	NR	100/38
AMMONIUM BICARBONATE	15	NR	120/49
AMMONIUM BISULFITE	--	NR	120/49
AMMONIUM CARBONATE	25	NR	100/38
AMMONIUM CITRATE	10	NR	120/49
AMMONIUM FLUORIDE	--	NR	120/49
AMMONIUM HYDROXIDE	5	NR	120/49
AMMONIUM HYDROXIDE	10	NR	120/49
AMMONIUM HYDROXIDE	20	NR	120/49
AMMONIUM NITRATE	15	120/49	150/65
AMMONIUM PERSULFATE	5 - 20	NR	150/65
AMMONIUM PHOSPHATE	--	NR	120/49
AMMONIUM SULFATE	15	120/49	150/65
ARESENIOS ACID	--	NR	160/71
BARIUM ACETATE	100	NR	NR
BARIUM CARBONATE	100	NR	NR
BARIUM CHLORIDE	100	NR	100/38
BARIUM HYDROXIDE	10	NR	NR
BARIUM SULFATE	100	NR	100/38
BARIUM SULFIDE	10	NR	NR
BEER	--	NR	120/49
BENZENE	100	NR	NR



# Chemical Compatibility Guide

## Benzene in Kerosene – Chromic Acid

Chemical Environment	Concentration Percentage	Pultex® Structural Profiles	
		1500/1525 Srs. Temp. Max F/C	1625 Srs. Temp. Max F/C
BENZENE IN KEROSENE	5	NR	160/71
BENZENE SULFURIC ACID	5 - 20	100/38	150/65
BENZOIC ACID	5 - 20	NR	100/38
O-BENZOYL BENZOIC ACID	--	NR	160/71
BENZYL ALCOHOL	100	NR	NR
BENZYL CHLORIDE	100	NR	NR
BORAX	5 - 20	100/38	150/65
BRASS PLATING SOLUTION	--	NR	160/71
BUTYL ACETATE	--	NR	NR
BUTYRIC ACID	5 - 30	NR	120/49
BUTYLENE GLYCOL	100	150/65	150/65
CADMIUM CHLORIDE	--	NR	160/71
CADMIUM CYANIDE PLATING	--	NR	120/49
CALCIUM BISULFITE	--	150/65	160/71
CALCIUM CARBONATE	10	NR	100/38
CALCIUM CHLORIDE	10	NR	100/38
CALCIUM CHLORATE	10	NR	100/38
CALCIUM HYDROXIDE	5 - 20	NR	100/38
CALCIUM HYPOCHLORITE	10	NR	120/49
CALCIUM NITRATE	5	120/49	150/65
CALCIUM SULFATE	10	120/49	150/65
CALCIUM SULFITE	--	150/65	160/71
CAPRYLIC ACID	--	NR	160/71
CARBON DIOXIDE	--	150/65	160/71
CARBON DISULFIDE	100	NR	NR
CARBON MONOXIDE GAS	--	100/38	150/65
CARBON TETRACHLORIDE	100	NR	100/38
CARBONIC ACID	10	100/38	120/49
CARBON METHYL CELLULOSE	--	NR	120/49
CASTOR OIL	100	150/65	150/65
CHLORINATED WAX	10	NR	120/49
CHLORINE DIOXIDE/AIR	--	NR	160/71
CHLORINE DIOXIDE, WET GAS	--	NR	160/71
CHLORINE DRY GAS	--	NR	160/71
CHLORINE WET GAS	--	NR	160/71
CHLORINE LIQUID	--	NR	NR
CHLORINE WATER	10	NR	120/49
CHLOROACETIC ACID	0 - 50	NR	100/38
CHLOROBENZENE	--	NR	NR
CHLOROFORM	100	NR	NR
CHLOROSULFONIC ACID	--	NR	NR
CHROMIC ACID	5	NR	100/38

# Chemical Compatibility Guide

## Chromic Acid – Ferric Chloride

Chemical Environment	Concentration	Pultex® Structural Profiles	
		1500/1525 Srs. Temp. Max	1625 Srs. Temp. Max
	Percentage	F/C	F/C
CHROMIC ACID	20	NR	120/49
CHROMIC ACID	30	NR	NR
CHROMIUM SULFATE	--	150/65	160/71
CITRIC ACID	5 - 30	120/49	150/65
COCONUT OIL	--	NR	160/71
COPPER CHLORIDE	5	150/65	180/82
COPPER CYANIDE	5	150/65	180/82
COPPER FLUORIDE	--	NR	160/71
COPPER NITRATE	--	150/65	NR
COPPER BRITE PLATING	--	NR	120/49
COPPER PLATING SOLUTION	--	NR	160/71
COPPER MATTE DIPPING BATH	--	NR	160/71
COPPER PICKLING BATH	--	NR	160/71
COPPER SULFATE	--	150/65	160/71
CORN OIL	100	NR	100/38
CORN STARCH- SLURRY	--	NR	160/71
CORN SUGAR	100	NR	150/65
COTTONSEED OIL	--	NR	160/71
CRUDE OIL	100	NR	150/65
CYCLOHEXENE	--	NR	120/49
CYCLOHEXENE VAPOR	--	NR	NR
DEIONIZED WATER	--	150/65	150/65
DETERGENTS SULFONATED	--	NR	160/71
DI-AMMONIUM PHOSPHATE	--	NR	160/71
DIBROMOPHENOL	--	NR	NR
DIBUTYL ETHER	--	NR	120/49
DICHLORO BENZENE	--	NR	NR
DICHLOROETHYLENE	--	NR	NR
DIETHYLENE GLYCOL	--	NR	160/71
DIETHYL ETHER	100	NR	NR
DIMENTHYL PHTHALATE	--	NR	160/71
DIOCTYL PHTHALATE	--	NR	160/71
DIPROPYLENE GLYCOL	100	NR	120/49
DODECYL ALCOHOL	--	NR	160/71
ESTER, FATTY ACIDS	--	150/65	160/71
ETHYL ACETATE	100	NR	NR
ETHYL BENZENE	--	NR	NR
ETHYL ETHER	--	NR	NR
ETHYLENE GLYCOL	100	100/38	150/65
ETHYLENE DICHLORIDE	--	NR	NR
FATY ACIDS	10	120/49	150/65
FERRIC CHLORIDE	10	120/49	150/65

# Chemical Compatibility Guide

## Ferric Nitrate – Hydrogen Fluoride Vapors

Chemical Environment	Concentration Percentage	Pultex® Structural Profiles	
		1500/1525 Srs. Temp. Max F/C	1625 Srs. Temp. Max F/C
FERRIC NITRATE	10	120/49	150/65
FERRIC SULFATE	10	120/49	150/65
FERROUS CHLORIDE	--	150/65	160/71
FERROUS NITRATE	--	150/65	160/71
FERROUS SULFATE	--	150/65	160/71
8-8-8 FERTILIZER	--	NR	120/49
FLUOBORIC ACID	--	NR	120/49
FLUSOILICIC ACID	--	NR	160/71
FORMALDEHYDE	5 - 30	NR	100/38
FORMIC ACID	25	NR	100/38
FUEL GAS	--	NR	160/71
FUEL OIL	100	NR	100/38
GAS NATURAL	--	NR	160/71
GASOLINE AUTO	--	NR	160/71
GASOLINE AVIATION	--	NR	160/71
GASOLINE ETHYL	--	NR	160/71
GASOLINE SOUR	--	NR	160/71
GLUCONIC ACID	--	NR	160/71
GLUCOSE	100	150/65	180/82
GLYCERIN	100	150/65	180/82
GLYCOL ETHYLENE	--	150/65	160/71
GLYCOL PROPYLENE	--	150/65	160/71
GLYCOLIC ACID	--	NR	160/71
GOLD PLATING SOLUTION	--	NR	160/71
HEPTANE	100	100/38	150/65
HEXANE	100	100/38	150/65
HEXALENE GLYCOL	--	150/65	160/71
HYDRAULIC FLUID	100	NR	120/49
HYDROBROMIC ACID	5 - 50	100/38	150/65
HYDROCHLORIC ACID	10 - 30	NR	120/49
HYDROCYANIC ACID	--	150/65	160/71
HYDROFLUORIC ACID	--	NR	NR
HYDROFLOUSILIC ACID	10	NR	160/71
HYDROZINE	100	NR	NR
HYDROGEN BROMIDE, DRY	--	NR	NR
HYDROGEN BROMIDE, WET GAS	--	NR	160/71
HYDROGEN CHLORIDE, DRY GAS	--	NR	160/71
HYDROGEN CHLORIDE, WET GAS	--	NR	160/71
HYDROGEN PEROXIDE	--	NR	120/49
HYDROGEN SULFIDE DRY	--	NR	160/71
HYDROGEN SULFIDE AQUEOUS	--	NR	160/71
HYDROGEN FLUORIDE VAPORS	--	NR	NR

# Chemical Compatibility Guide

## Hydrosulfite Bleach – Myristic Acid

Chemical Environment	Concentration Percentage	Pultex® Structural Profiles	
		1500/1525 Srs. Temp. Max	1625 Srs. Temp. Max
		F/C	F/C
HYDROSULFITE BLEACH	--	NR	120/49
HYPOCHLORUS ACID	--	NR	160/71
IRON PLATING SOLUTION	--	NR	160/71
IRON & STEEL CLEANING BATH	--	NR	160/71
ISOPROPYL AMINE	--	NR	100/38
ISOPROPYL PAMITATE	--	150/65	160/71
JET FUEL	--	NR	160/71
KEROSENE	--	NR	160/71
LACTIC ACID	--	NR	160/71
LAUROYL CHLORIDE	--	NR	160/71
LAURIC ACID	--	NR	160/71
LEAD ACETATE	100	NR	120/49
LEAD CHLORIDE	10	120/49	150/65
LEAD NITRATE	10	NR	100/38
LEAD PLATING SOLUTION	--	NR	160/71
LEVULINIC ACID	--	NR	160/71
LINSEED OIL	--	150/65	160/71
LITHIUM BROMIDE	--	150/65	160/71
LITHIUM CHLORIDE	25	NR	120/49
LITHIUM SULFATE	--	150/65	160/71
LITHIUM HYDROXIDE	10	NR	120/49
MAGNESIUM BISUFITE	--	NR	160/71
MAGNESIUM CARBONATE	10	100/38	150/65
MAGNESIUM CHLORIDE	10	100/38	150/65
MAGNESIUM HYDROXIDE	10	NR	120/49
MAGNESIUM NITRATE	10	NR	120/49
MAGNESIUM SULFATE	10	100/38	120/49
MALEIC ACID	100	150/65	150/65
MERCURIC CHLORIDE	10	120/49	150/65
MERCUROUS CHLORIDE	10	120/49	150/65
METHANOL	--	NR	160/71
METHYLENE CHLORIDE	--	NR	NR
METHYL ETHYL KETONE @120F	--	NR	NR
METHYL ISOBUTYL CARBITOL	--	NR	NR
METHYL ISOBUTYL KETONE	--	NR	NR
METHYL STYRENE	--	NR	NR
MINERAL OIL	100	150/65	150/65
MOLYBDENUM DISULFIDE	--	NR	160/71
MONOCHLORIC ACETIC ACID	--	NR	NR
MONOETHANOLAMINE	--	NR	NR
MOTOR OIL	100	150/65	150/65
MYRISTIC ACID	--	--	160/71

# Chemical Compatibility Guide

## Naptha – Potassium Dichromate

Chemical Environment	Concentration	Pultex® Structural Profiles	
		1500/1525 Srs. Temp. Max	1625 Srs. Temp. Max
	Percentage	F/C	F/C
NAPHTHA	100	150/65	150/65
NICKEL CHLORIDE	10	120/49	150/65
NICKEL NITRATE	10	120/49	150/65
NICKEL PLATING: .4% Boric Acid	--	NR	160/71
NICKEL PLATING: 11% Nickel Sulfate, 2% Nickel Chloride, 1% Boric Acid	--	NR	160/71
NICKEL PLATING: 44% Nickel Sulfate, 2% Ammonium Chloride, 4% Boric Acid	--	NR	160/71
NICKEL SULFATE	10	120/49	150/65
NITRIC ACID	5 - 30	NR	100/38
NITRIC ACID FUMES	--	NR	NR
NITROBENZENE	--	NR	NR
OCTANOIC ACID	--	NR	160/71
OIL, SOUR CRUDE	100	NR	120/49
OIL SWEET CRUDE	100	NR	120/49
OLEIC ACID	100	120/49	150/65
OLEUM (FUMING SULFURIC)	--	NR	NR
OILVE OIL	--	150/65	160/71
OXALIC ACID	--	150/65	160/71
PEROXIDE BLEACH: 2% Sodium Peroxide- 96% .025 Epsom Salts, 5% Sodium Silicate 42° Be, 1.4% Sulfuric Acid 66° Be	--	150/65	160/71
PHENOL	10	NR	NR
PHENOL SULFONIC ACID	--	NR	NR
PHOSPHORIC ACID	5 - 50	100/38	150/65
PHOSPHORIC ACID FUMES	--	150/65	160/71
PHOSPHORUS			
PENTOXIDE	--	150/65	160/71
PHOSPHOROUS TRICHLORIDE	100	NR	NR
PHTHALIC ACID	100	NR	120/49
PICKLING ACIDS: Sulfuric and Hydrochloric	--	150/65	160/71
PICRIC ACID ALCOHOLIC	--	150/65	160/71
POLYVINYL ACETATE LATEX	--	NR	160/71
POLYVINYL ALCOHOL	100	NR	100/38
POLYVINYL CHLORIDE LATEX: With 35(Parts Drop)	--	NR	120/49
POTASSIUM ALUMINUM SULFATE	10	120/49	150/65
POTASSIUM BICARBONATE	--	NR	120/49
POTASSIUM BROMIDE	10	NR	120/49
POTASSIUM CARBONATE	10	NR	120/49
POTASSIUM CHLORIDE	100	NR	120/49
POTASSIUM DICHROMATE	100	NR	120/49

## Chemical Compatibility Guide

### Potassium Ferricyanide – Sodium Hexametaphosphates

Chemical Environment	Concentration Percentage	Pultex® Structural Profiles	
		1500/1525 Srs. Temp. Max	1625 Srs. Temp. Max
		F/C	F/C
POTASSIUM FERRICYANIDE	--	150/65	160/71
POTASSIUM HYDROXIDE	10	NR	150/65
POTASSIUM NITRATE	10	120/49	150/65
POTASSIUM PERMANGANTE	100	100/38	150/65
POTASSIUM PERSULFATE	--	NR	160/71
POTASSIUM SULFATE	10	120/49	150/65
PROPIONIC ACID	1 - 50	NR	120/49
PROPIONIC ACID	50 - 100	NR	NR
PROPYLENE GLYCOL	100	150/65	150/65
PULP PAPER MILL EFFLUENT	--	NR	160/71
PYRIDINE	--	NR	NR
SALICYLIC ACID	--	NR	140/60
SEA WATER	--	150/65	150/65
SEWAGE TREATMENT	--	NR	100/38
SEBACIC ACID	--	NR	160/71
SELENIOUS ACID	--	NR	160/71
SILVER NITRATE	--	150/65	160/71
SILVER PLATING SOLUTION: 4% Silver Cyanide, 7% Potassium, 5% Sodium Cyanide, 2% Potassium Carbonate	--	NR	160/71
SOAPS	--	NR	160/71
SODIUM ACETATE	--	NR	160/71
SODIUM BENZOATE	--	NR	160/71
SODIUM BICARBONATE	--	150/65	160/71
SODIUM BIFLUORIDE	--	NR	160/71
SODIUM BISULFATE	--	150/65	160/71
SODIUM BISULFITE	--	150/65	160/71
SODIUM BROMATE	--	150/65	140/60
SODIUM BROMIDE	--	150/65	160/71
SODIUM CARBONATE	0 - 25	NR	160/71
SODIUM CHLORATE	--	NR	160/71
SODIUM CHLORIDE	--	150/65	160/71
SODIUM CHLORITE	25	NR	160/71
SODIUM CHROMATE	--	150/65	160/71
SODIUM CYANIDE	--	NR	160/71
SODIUM DICHROMATE	--	150/65	160/71
SODIUM DI-PHOSPHATE	--	150/65	160/71
SODIUM FERRICYANIDE	--	150/65	160/71
SODIUM FLUORIDE	--	NR	120/49
SODIUM FLOURO SILICATE	--	NR	120/49
SODIUM HEXAMETAPHOSPHATES	--	NR	100/38

# Chemical Compatibility Guide

## Sodium Hydroxide – Tin Plating Solution

Chemical Environment	Concentration Percentage	Pultex® Structural Profiles	
		1500/1525 Srs. Temp. Max	1625 Srs. Temp. Max
		F/C	F/C
SODIUM HYDROXIDE	0 – 5	NR	150/65
SODIUM HYDROXIDE	5 - 25	NR	150/65
SODIUM HYDROXIDE	50	NR	150/65
SODIUM HYDROSULFATE	--	NR	160/71
SODIUM HYPOCHLORITE	10	NR	120/49
SODIUM LAURYL SULFATE	--	150/65	160/71
SODIUM MONO-PHOSPHATE	--	150/65	160/71
SODIUM NITRATE	--	150/65	160/71
SODIUM SILICATE	--	NR	120/49
SODIUM SULFATE	--	150/65	160/71
SODIUM SULFIDE	--	NR	120/49
SODIUM SULFITE	--	NR	120/49
SODIUM TETRA BORATE	--	150/65	160/71
SODIUM THIOCYANATE	--	NR	160/71
SODIUM THIOSULFATE	--	NR	160/71
SODIUM POLYOPHOSPHATE	--	NR	160/71
SODIUM XYLENE SULFONATE	--	NR	160/71
SODIUM SOLUTIONS	--	NR	160/71
SODIUM CRUDE OIL	--	150/65	160/71
SOVA OIL	--	150/65	160/71
STANNIC CHLORIDE	--	150/65	160/71
STANNOUS CHLORIDE	--	150/65	160/71
STEARIC ACID	--	150/65	160/71
STYRENE	--	NR	NR
SUGAR, BEET AND CANE LIQUOR	--	NR	160/71
SUGAR, SUCROSE	--	150/65	160/71
SULFAMIC ACID	--	NR	160/71
SULFANILIC ACID	--	NR	160/71
SULFATED DETERGENTS	--	NR	160/71
SULFUR DIOXIDE, WET OR DRY	--	NR	160/71
SULFUR, TRIOXIDE/AIR	--	NR	160/71
SULFURIC ACID	0 - 30	150/65	160/71
SULFURIC ACID	30 - 50	NR	160/71
SULFURIC ACID	50 - 70	NR	120/49
SULFUROUS ACID	10	NR	100/38
SUPERPHOSPHORIC ACID: 76% P205	--	NR	160/71
TALL OIL	--	NR	150/65
TANNIC ACID	--	NR	120/49
TARTARIC ACID	--	150/65	160/71
THIONYL CHLORIDE	--	NR	NR
TIN PLATING SOLUTION: 18% Stannous Fluoroborate, 7% Tin, 9% Fluoroboric acid, 2% Boric Acid	--	NR	160/71

# Chemical Compatibility Guide

## Toluene – Zinc Sulfate

Chemical Environment	Concentration Percentage	Pultex® Structural Profiles	
		1500/1525 Srs. Temp. Max	1625 Srs. Temp. Max
		F/C	F/C
TOLUENE	--	NR	NR
TOLUENE SOLFONIC ACID	--	NR	160/71
TRANSFORMER OILS: Mineral Oil Types, Chloro-phenyl Types	--	NR	NR
TRICHLOR ACETIC ACID	50	NR	160/71
TRICHLORETHYLENE	--	NR	NR
TRICHLOROPENOL	--	NR	NR
TRICRESYL PHOSPHATE +A618	--	NR	120/49
TRIDECYLBENZENE SULFONATE	--	NR	160/71
TRISODIUM PHOSPHATE	--	NR	160/71
TURPENTINE	--	NR	100/38
UREA	--	NR	140/60
VEGETABLE OILS	--	150/65	160/71
VINEGAR	--	150/65	160/71
VINYL ACETATE	--	NR	NR
WATER:			
DEIONIZED	--	150/65	160/71
DEMINERALIZED	--	150/65	160/71
DISTILLED	--	150/65	160/71
FRESH	--	150/65	160/71
SALT	--	150/65	160/71
SEA	--	150/65	160/71
WHITE LIQUOR (Pulp Mill)	--	NR	160/71
XYLENE	--	NR	NR
ZINC CHLORATE	--	150/65	160/71
ZINC NITRATE	--	150/65	160/71
ZINC PLATING SOLUTION: 9% Zinc Cyanide, 4% Sodium Cyanide, 9% Sodium Hydroxide	--	NR	120/49
ZINC PLATING SOLUTION: 49% Zinc Fluoroborate, 5% Ammonium Chloride, 6% Ammonium Fluoroborate	--	NR	160/71
ZINC SULFATE	--	150/65	160/71



# **SECTION 9**

## **DESIGNING FLEXURAL MEMBERS (BEAMS)**

This section of the AIMS International, LLC Fiberglass Structural Design Manual is credited to Strongwell, Inc. All beam equations in this section were taken from the 1989 edition of the Extren<sup>®</sup> Design manual

## SYMBOLS FOR FLEXURAL MEMBERS (BEAMS)

$A_w$	=	Cross-sectional area of web or webs (in <sup>2</sup> )
$B$	=	Derived constant for use in Eq. B-5
$C_1$	=	Lateral buckling coefficient from Table 9-1
$E$	=	Modulus of Elasticity about X-X or Y-Y axis (psi)
$F_b$	=	Allowable flexural stress (psi)
$F_b'$	=	Allowable flexural stress-laterally unsupported beams (psi)
$F_u$	=	Ultimate flexural stress-laterally supported beams (psi)
$F_u'$	=	Ultimate flexural stress-laterally unsupported beams (psi)
$F_v$	=	Allowable shear stress (psi)
$G$	=	Shear modulus (psi)
$I_x, I_y$	=	Moment of inertia about X-X or Y-Y axis (in <sup>4</sup> )
$J$	=	Torsional constant (in <sup>4</sup> )
$K_x, K_y$	=	Effective length factor for buckling about X-X or Y-Y axis
$K_b$	=	Coefficient for flexural deflection
$K_v$	=	Coefficient for shear deflection
$L$	=	Length of beam (center to center of supports) (ft)
$L_u$	=	Unbraced length of beam (center to center of lateral braces) (ft)
$M$	=	Bending moment from applied loads (lb-in)
$N$	=	Derived constant for use in Eq. B-5
$P$	=	Concentrated load on beam (lbs)
$S_x, S_y$	=	Section Modulus about X-X or Y-Y axis (in <sup>3</sup> )
$V$	=	Shear from applied load (lbs)
$W$	=	Uniform beam load (lbs/ft)
$W_t$	=	Weight of section (lbs)
$b$	=	Outside dimensions of square tube (in)
$b_f$	=	Width of flange (in)
$d$	=	Full depth of section (in)
$f_b$	=	Flexural stress from applied loads (psi)
$f_v$	=	Shear stress from applied load (psi)
$l$	=	Length of beam (center to center of supports) (in)
$l_u$	=	Unbraced length of beam (center to center of lateral braces) (in)
$t$	=	Thickness of section (in) or wall thickness of tubes (in)
$t_f$	=	Thickness of flange (in)
$t_w$	=	Thickness of web (in)
$w$	=	Uniform beam load (lb/in)
$\Delta$	=	Deflection (in)
S.F.	=	Safety factor

# BEAM BENDING EQUATIONS

Flexural members have two primary failure modes due to bending: 1) failure due to pure bending stress, i.e. compression flange crushing or tension flange breaking and 2) failure due to global buckling, i.e. lateral torsional buckling. Proper design of flexural members requires that both of these failure modes be investigated in the design process.

Examination of these failure modes indicates that the compression flange bracing is critical in determining the maximum allowable flexural stress. Allowable stress will be reduced significantly if the proper bracing scheme is not used. The use of intermediate beams at the appropriate spacing along the bending member can be used to eliminate buckling concerns. These failure modes must be analyzed carefully when selecting a beam member.

## MAJOR AXIS BENDING

### STRESSES FROM APPLIED LOADS IN THE PLANE OF THE WEB

Flexural Stress  $f_b = M/S_x$  Equation B-1

Shear Stress  $f_v = V/A_w$  Equation B-2

### Laterally Supported W & I Shapes

Equation B-3

Ultimate  $F_u = 0.5E/[(b_f/t_f)^{1.5}]$  < 30,000 psi Isophthalic Polyester resin  
< 30,000 psi Vinyl Ester resin (member larger than 4")  
< 33,000 psi Vinyl Ester resin (members 4" and smaller)

Allowable  $F_b = F_u/S.F. = F_u/2.5$  Equation B-4

### **Laterally Unsupported W & I Shapes**

$$\text{Ultimate } F_u' = C_1/S_x [(N^2 + (d^2 B^2 / 4))]^{1/2}$$

$< 30,000$  psi Isophthalic Polyester resin  
 $< 30,000$  psi Vinyl Ester resin      Equation B-5  
 $< 33,000$  psi Vinyl Ester resin (members 4" and smaller)

$$\text{Where } N = \pi / (K_y l_u) [(EI_y GJ)^{1/2}]$$

$$\text{And } B = \pi^2 EI_y / [(K_y l_u)^2]$$

$$\text{Allowable } F_b' = F_u' / S.F. = F_u' / 2.5 \qquad \qquad \qquad \text{Equation B-6}$$

$K_y$  and  $C_1$  values used in equations B-5 and B-6 are from Table 9-1 and reflect the beams end conditions in the Y-Y Axis and loading on the beam.

### **Laterally Supported Or Laterally Unsupported Square and Rectangular Tubing:**

$$\text{Ultimate } F_u = E / [16(b/t)^{0.85}]$$

$< 30,000$  psi Isophthalic Polyester resin  
 $< 33,000$  psi Vinyl Ester resin      Equation B-7  
 $< 35,000$  psi Vinyl Ester resin (Large Rectangular Shapes)

$$\text{Allowable } F_b = F_u / S.F. = F_u / 2.5 \qquad \qquad \qquad \text{Equation B-8}$$

### **Laterally Supported Channels**

$$\text{Ultimate } F_u = E / [27(b_f/t_f)^{0.95}]$$

$< 30,000$  psi Isophthalic Polyester resin  
 $< 33,000$  psi Vinyl Ester resin      Equation B-9

$$\text{Allowable } F_b' = F_u' / S.F. = F_u' / 2.5 \qquad \qquad \qquad \text{Equation B-10}$$

It must be stressed that a non-symmetrical shape such as channel should only be used when the flanges are adequately laterally supported. Current industry experience has shown that satisfactory performance from channels has been achieved when the compression flange was laterally supported with connecting members at the following spacings:

- 24" maximum for C3 and C4 channels
- 36" maximum for C5 and C6 channels
- 48" maximum for C8 channels and larger

## MINOR AXIS BENDING

None of the major pultrusion companies address minor axis bending. AIMS International has adopted the position to limit the flexural stresses on the extreme fibers of fiberglass beams, bent about their minor axis, to the same allowable stresses calculated as beams bent about their major axis.

Thus,

$$F_{by} = F_{bx} \quad \text{Equation B-13}$$

Where;  $F_{by}$  = allowable flexural stress about the minor axis, Y-Y,

and

$F_{bx}$  = allowable flexural stress about the major axis, X-X.

## DEFLECTIONS

Structural shapes with uniform loads, w:

$$\Delta = K_b[(wl^4/EI_x)] + K_v[(wl^2/A_wG)] \quad \text{Equation B-16}$$

where  $A_w = t_w \times d$

Structural shapes with concentrated loads, P:

$$\Delta = K_b[(Pl^3/EI_x)] + K_v[(Pl/A_wG)] \quad \text{Equation B-17}$$

where  $A_w = t_w \times d$

$K_b$  is taken from Table 9-2 and reflects the beam end conditions.

For beams with supports at both ends,  $K_v=0.35$ . This value actually varies slightly depending on load distribution, end constraints and Poisson's Ratio, but the given value will be adequate for most cases with supports at both ends of the beam.  $K_v=1.2$  for cantilever beams. For additional information see *Mechanics of Materials* – Timoshenko, S. P. and Gere, J.S., Van Nostrand, 1972.

## TABLE 9-1

### LATERAL BUCKLING COEFFICIENTS FOR BEAMS WITH VARIOUS LOAD AND SUPPORT ARRANGEMENTS

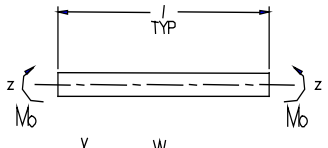
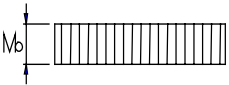
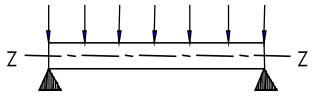
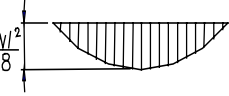
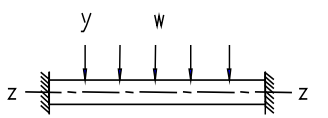
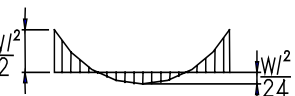
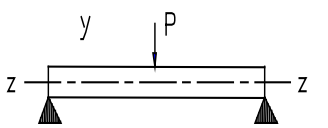
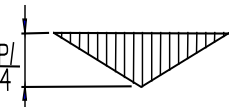
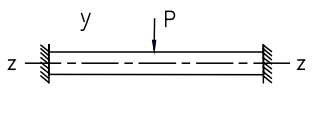
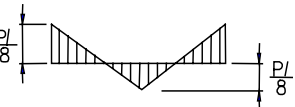
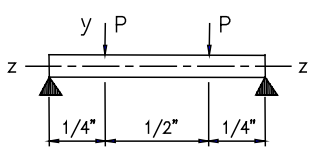
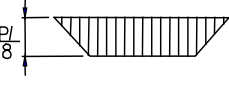
Loading and end Restraint* about X-axis	Bending moment diagram	End restraint about Y-axis	K <sub>y</sub>	C <sub>1</sub> *
		None	1.0	1.0
		None Full	1.0 0.5	1.13 0.97
		None Full	1.0 0.5	1.30** 0.86**
		None Full	1.0 0.5	1.35 1.07
		None Full	1.0 0.5	1.70 1.04
		None	1.0	1.04

\* All beams are restrained at each end against rotation about the X-axis and displacement in the Y and Z directions. Loads applied at beam centroidal axis.

\*\* Critical Stress based on center moment ( $Wl^2/24$ ).

Table taken from Structural Plastics Design Manual –American Society of Civil Engineers, 345 East 47<sup>th</sup> Street, New York, NY, 10017, Volumes 1 and 2, September 1981.

## TABLE 9-2

COEFFICIENTS  $K_b$  – FOR FLEXURAL DEFLECTION

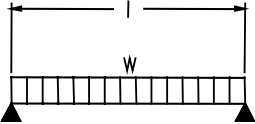
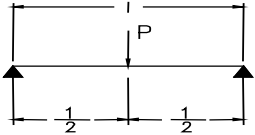
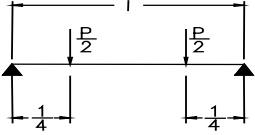
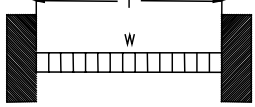
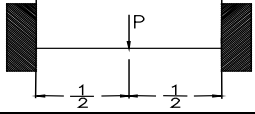
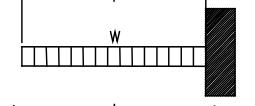
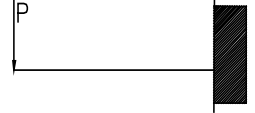
END SUPPORT	TYPE OF LOADING	DEFLECTION AT:	$K_b$
Simple Support @ Both Ends		Midspan	0.013
		Midspan	0.021
		Midspan Quarter Pts.	0.029 0.021
Fixed Support @ Both ends		Midspan	0.003
		Midspan	0.005
Cantilever		Free End	0.125
		Free End	0.333

## **SECTION 10**

### **DESIGNING TENSION MEMBERS**



## Tension

Allowable tensile stress along the major axis (lengthwise, LW) is calculated by using the Tensile Strength LW,  $F_{ut-lw}$  (from Section 4) and divided by a Safety Factor of 4.0 (see Section 6). We calculate the allowable tensile stress as:

$$F_{t(lw)} = F_{ut-lw}/S.F. = 33,000/4.0 = 8250 \text{ psi for Series 1500/1525} \quad \text{Equation 10-1a}$$

$$= 37,500/4.0 = 9375 \text{ psi for Series 1625} \quad \text{Equation 10-1b}$$

\* Please note that the above calculations are based upon the properties of the “standard” Pultex<sup>®</sup> shapes and not the Pultex<sup>®</sup> SuperStructural shapes. When using Pultex<sup>®</sup> SuperStructural shapes higher values of  $F_{t(lw) \text{ ult}}$  can be used. Refer to Section 4, pages 20-22 for Super Structural values.

Determination of the actual tensile stress is determined by the formula,

$$f_t = P/A \leq F_{t(lw)} \quad \text{Equation 10-2}$$

where,

P = tensile load in the member

A = cross sectional area of the tension member

Allowable tensile stress perpendicular to the major axis (crosswise, CW) is calculated by using the ultimate tensile strength CW,  $F_{ut-cw}$  (from Section 4) and dividing it by a Safety Factor of 4.0 (see Section 6).

$$F_{t(cw)} = F_{ut-cw}/S.F. = 7,500/4.0 = 1,875 \text{ psi for Series 1500/1525} \quad \text{Equation 10-3a}$$

$$= 8,000/4.0 = 2,000 \text{ psi for Series 1625} \quad \text{Equation 10-3b}$$

\* Please note that the above calculations are based upon the properties of the “standard” Pultex<sup>®</sup> shapes and not the Pultex<sup>®</sup> SuperStructural shapes. When using Pultex<sup>®</sup> SuperStructural shapes higher values of  $F_{t(lw) \text{ ult}}$  can be used. Refer to Section 4, pages 20-22 for Super Structural values.

# **SECTION 11**

## **DESIGNING COMPRESSION MEMBERS (COLUMNS)**

This section of the AIMS International, LLC Fiberglass Structural Design Manual is credited to Creative Pultrusions, Inc.

## Symbols for Compression Members (Columns)

A	=	Cross-sectional area (in <sup>2</sup> )
$\alpha$	=	Width of local flange element; width of angle leg or ½ width of a wide flange beam (in)
E	=	Modulus of elasticity in the loading direction (psi)
F <sub>a</sub>	=	Allowable compressive stress (psi)
I <sub>x</sub> , I <sub>y</sub>	=	Moment of Inertia (in <sup>4</sup> )
k	=	Flange stiffness factor 0.5 for non-stiffened outstanding flanges of the W-section; 4.0 for stiffened
K	=	Effective length coefficient
L	=	Length of column (ft); (in) when used in KL/r equation
P <sub>a</sub>	=	Allowable axial load (lbs)
r	=	Radius of gyration of the section (in)
S	=	Section Modulus (in <sup>3</sup> )
t <sub>f</sub>	=	Thickness of local flange element (in)
$\nu$	=	Poisson's Ratio
$\Phi$	=	0.8, a coefficient to account for the orthotropic material of the composite
$\sigma_{ult}$	=	Ultimate compressive or bearing stress of the composite (psi)
$\sigma_{ult,l}$	=	Ultimate local buckling stress (psi)
$\sigma_{ult,Eluer}$	=	Ultimate Euler buckling stress (psi)
$\sigma_{ult,ft}$	=	Ultimate flexural-torsional buckling stress (psi)

## Column Load Design Equations

The Column Load Design Equations for E-Glass reinforced polymer columns are based on a large group of data points from full section tests of composite columns. The observed column failure can be categorized into two modes: bearing failure and local/global instability. Figure 11-1 depicts a general behavior for all fiber reinforced polymer columns. The curve can be divided into two groups: short column and long column, as the plotted compressive stress versus slenderness ratio. The short columns generally fail in bearing deformation or local buckling mode; the long columns generally fail in the global buckling mode.

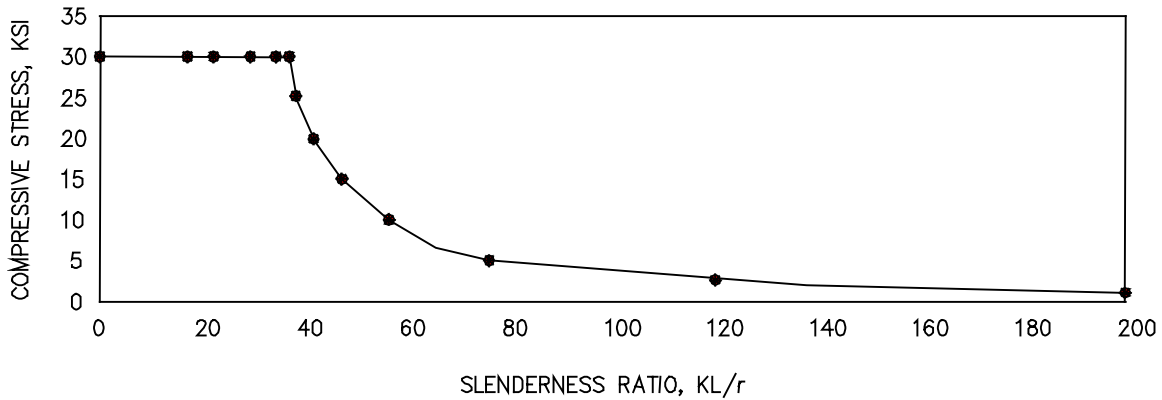

Figure 11-1. Typical column strength curve

## Design Equations for Box Sections

For short columns with box sections, a bearing failure due to axial compressive loading governs the design equation as follows:

$$\sigma_{ult} = P_{ult}/A$$

Equation C-1

Where  $P_{ult}$  = Ultimate axial load (lbs)  
 $A$  = Cross-sectional area (in<sup>2</sup>)  
 $\sigma_{ult}$  = Bearing strength of the composite (psi)

### Columns with Round and I-Sections

For short columns with round and I-sections, the columns fail due to a combination of axial load and bending moment. The design equations consider the interaction of bearing and flexural buckling failure. A linear equation is developed from the test results for the transition behavior as follows:

$$\sigma_{ult} = 30 - [(1/7)(KL/r)] \text{ (ksi) for short FRP Round-section columns} \quad \text{Equation C-2}$$

$$\sigma_{ult} = 25 - [(5/38)(KL/r)] \text{ (ksi) for short FRP I-section columns} \quad \text{Equation C-3}$$

Where  $\sigma_{ult}$  = Ultimate compressive stress (ksi)  
K = Effective length coefficient (Table 11-1)  
L = Column length (in) when used in above equation  
r = Radius of gyration of the section (in)

### Columns of W-Sections

For short columns with W-sections, local buckling or crippling occurs on the flanges. According to the test results, the ultimate local buckling stress  $\sigma_{ult,l}$  of the Pultex<sup>®</sup> FRP composite W-section column can be predicted by the modified buckling equation of thin plate for isotropic materials as follows:

$$\sigma_{ult,l} = \Phi k (\pi^2 E / [12(1-\nu^2)]) (t_f / \alpha)^2 \text{ (psi) for short FRP W-section columns} \quad \text{Equation C-4}$$

Where E = Modulus of elasticity in the loading direction (psi)  
 $\nu$  = Poisson's ratio (see Section 4)  
 $t_f$  = Thickness of the local flange element (in)  
 $\alpha$  = Width of the local flange element (in)  
 $\Phi$  = 0.8, a coefficient to account for the orthotropic material of the composite  
k = 0.5 is recommended for the non-stiffened outstanding flanges of the W-section  
k = 4.0 is recommended for the stiffened outstanding webs of the W-section

It should be noted that the ultimate local buckling strength needs to be checked against bearing strength. The lower value will be used for the ultimate strength of the short composite column with the W-section. Then, the ultimate strength of the short column is compared with the flexural buckling strength to determine the dividing point for short and long columns.

## Columns with Angle Sections

For short columns with angle sections, the local buckling of the flange occurs, as in the column with the W-section. Thus, the design Equation (C-4) can also be applied to predict the ultimate strength of the short columns with angle sections.

## Design Equations for Long Columns

The flexural buckling, known as Euler buckling, is the general behavior of long, slender Pultex<sup>®</sup> FRP columns under axial compression loads. According to the test results, the ultimate buckling strength of the composite columns was in agreement with the Euler buckling equation:

$$\sigma_{ult,Euler} = \pi^2 E / [(KL/r)^2] \text{ (psi) for all long FRP Columns} \quad \text{Equation C-5}$$

The equation can be applied to the long Pultex<sup>®</sup> FRP composite columns with square, round, I, W, and angle sections; however, for columns with angle-sections, flexural-torsional buckling governs the ultimate strength. In the test, the coupling of the flexural and torsional buckling was observed in a form of lateral deflection and global twisting for the angle-section columns. The ultimate flexural-torsional buckling stress can be approximated by the lower value from equation (C-5) for flexural buckling strength about the weak axis, or from the torsional buckling equation as follows:

$$\sigma_{ult,ft} = \Phi (E/[2(1+\nu)]) (t_f/\alpha)^2 \text{ (psi) for short FRP Angle columns} \quad \text{Equation C-6}$$

According to the test results, the coefficient  $\Phi = 0.8$  is recommended for Equation C-6 to account for the orthotropic material of the composite, where  $b_f$  is the width of the local flange element (in); one-half the width for W-Sections; whole leg width for angle sections.

The effective length coefficient “K-value”, in the equation, accounts for the different end conditions. The “K-value” is recommended in Table 11-1 for Pultex<sup>®</sup> FRP composite columns with various end supports.

Table 11-1. Effective Length Coefficient, K-Value

End Conditions	Recommended K-Value
1. Pinned-Pinned	1.00
2. Fixed-Fixed	0.65
3. Pinned-Fixed	0.80
4. Fixed-Translation Fixed	1.20
5. Fixed-Translation Free	2.10
6. Pinned-Translation Fixed	2.00

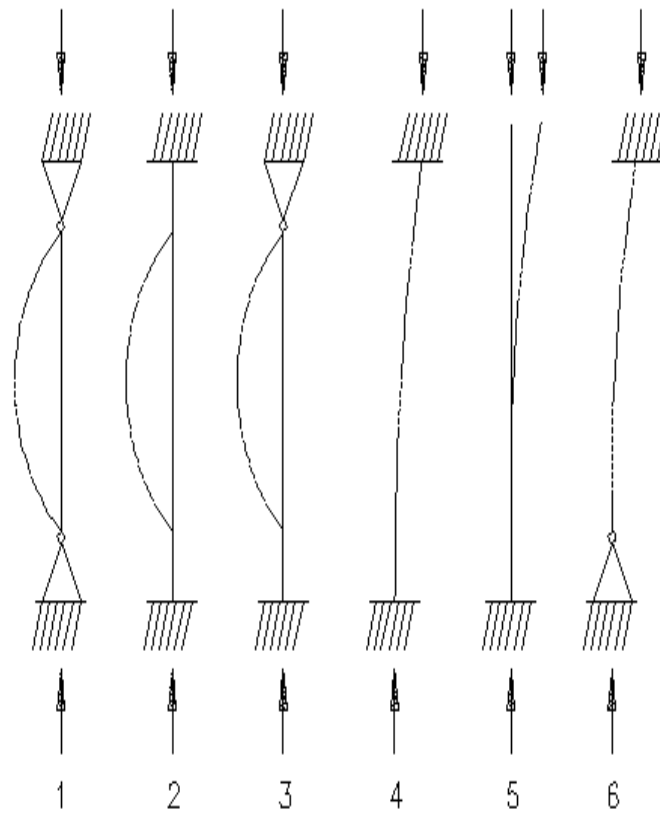

Note: Buckled Shape of Column Shown by Dashed Line

# **SECTION 12**

## **DESIGNING FOR SHEAR**



## SYMBOLS FOR SHEAR CALCULATIONS

$A_V$	=	Shear Area (in <sup>2</sup> )
$F_{Vult-LW}$	=	Ultimate Lengthwise Shear Strength (psi)
$F_{Vult-CW}$	=	Ultimate Crosswise Shear Strength (psi)
$F_V$	=	Allowable Shear Stress (psi)
S.F.	=	Safety factor (= 3.0 for beam shear, 4.0 for connections)
$f_v$	=	Actual Shear Stress (psi)

The allowable shear stress,  $F_v$  is calculated by dividing the Ultimate Short Beam Shear (see Section 4 for shear values) by the Shear Safety Factor, 3.0 or 4.0 (see Section 6). The Shear Safety Factor to be utilized when checking beam shear in a beam shall be 3.0. The Shear Safety Factor when calculating beam shear capacity of a clip angle at a connection shall be 4.0. The engineer shall take into account the direction of loading to properly choose either LW or CW Ultimate Shear values,  $F_{Vult-LW}$  or  $F_{Vult-CW}$ .

Thus

$$F_v = , F_{Vult-LW} \text{ or } F_{Vult-CW} / S.F., \text{ psi}$$

The actual shear stress,  $f_v$ , is calculated by the formula:

$$f_v = \frac{V}{A_w} ; \quad \text{Where } V \text{ is the beam shear force and } A_w \text{ is the cross sectional area of the web, or webs in the case of a rectangular or square tube.}$$

In short beams subjected to high concentrated loads, shear stress may govern the beam selection as opposed to the flexural stress.

## **SECTION 13**

### **COMBINING STRESSES FOR UNITY RATIOS**

## Combined Axial and Bending Stresses

When checking stresses at any given point in a beam or column, the engineer must combine all stresses from major axis bending, minor axis bending, and axial tension or axial compression.

For cases involving combined bending and axial loads, the Unity Ratio, UR, is calculated as follows:

$$\text{UR} = f_{bx}/F_{bx} + f_{by}/F_{by} + (f_a/F_a \text{ or } f_t/F_t) \quad \begin{array}{l} \leq 1.0 \quad (\text{for operating conditions}) \\ \leq 1.33 \quad (\text{for storm conditions}) \\ \leq 1.33 \quad (\text{for operating conditions with} \\ \text{seismic activity}) \end{array}$$

where:

$f_{bx}$  = actual major axis bending stress

$f_{by}$  = actual minor axis bending stress

$f_a$  = actual compressive stress

$f_t$  = actual tensile stress

and

$F_{bx}$  = allowable major axis bending stress

$F_{by}$  = allowable minor axis bending stress

$F_a$  = allowable compressive stress

$F_t$  = allowable tensile stress

# **SECTION 14**

## **DESIGNING CONNECTIONS**

## **SYMBOLS FOR DESIGNING CONNECTIONS**

$A_V$	=	Shear Area (in <sup>2</sup> )
$F_{Vult-LW}$	=	Ultimate Lengthwise Shear Strength (psi)
$F_{Vult-CW}$	=	Ultimate Crosswise Shear Strength (psi)
$F_V$	=	Allowable Shear Stress (psi)
$F_{brgult-LW}$	=	Ultimate bearing stress in the direction parallel to the rovings
$F_{brgult-CW}$	=	Ultimate bearing stress in the direction perpendicular to the rovings
S.F.	=	Safety factor (4.0 for connections)

## Framed Connections

The structural engineer must consider the fact that fiberglass structures are typically designed to be removeable, thus all connections are to be bolted only unless otherwise specified to be epoxied on the construction drawings. Epoxying a joint is analogous to welding a joint in steel--it is permanent. When a joint is epoxied, the flexibility of removal is lost. However, when bolting a connection, to ensure that the effects of vibration do not loosen the bolts, a thread locking compound such as "Loctite" (or equal) should be used, as this will help to prevent the nuts from loosening.

When designing a connection, the engineer must know and answer the following question --- Is the joint to be bolted only, or is the joint to be bolted and epoxied, or is the joint to be epoxied only? This question drives the design of the connection.

Per Section 6, **all connections are to be designed using a Safety Factor of 4.0.** From section 4, we obtain the appropriate values for the Ultimate Short Beam Shear Stress and the Ultimate Bearing Stress (LW or CW). The engineer must take care to know the direction the force is acting and select the correct LW or CW values.

$$F_v = F_{Vult-LW} \text{ or } F_{Vult-CW}/S.F.$$
$$F_b = F_{brgult-LW} \text{ or } F_{brgult-CW} /S.F.$$

Note: When using Pultex<sup>®</sup> SuperStructural members, the engineer must evaluate if the forces are in the flange section or the web section of W and I shaped members and use the appropriate values for calculating the allowable stress. Also, if angle Pultex<sup>®</sup> SuperStructural members are used, the appropriate value for shear and bearing stress should be used. (Refer to Section 4).

AIMS International recommends that, whenever possible, all bolting hardware used should be 316 stainless steel. Avoid, whenever possible, the use of carbon steel (painted or galvanized) because the primary intent for the use of fiberglass structures is to maximize corrosion resistance. The use of fiberglass bolting hardware is recommended only when 316 stainless steel hardware will not withstand the corrosive environment.

## Bolted Connections

When designing bolted connections, there are four engineering checks to be performed.

Using the reaction load at the joint:

- 1) Check of beam shear on net throat area of a clip angle, S.F. = 4.0
- 2) Check of beam shear on the web areas of the beams, S.F. = 4.0\*
- 3) Check of bolt bearing on the web of the beams, S.F. = 4.0\*
- 4) Check of bolt shear, web of beams through the bolt, S.F. = 4.0

\* Epoxied bearing doubler plates may be required to satisfy the 4.0 safety factor at the connection. Remember, the Shear Safety Factor for a beam analysis performed at a location other than the connection is 3.0.

### Checking beam shear on the net throat area of a clip angle:

When checking beam shear on the net throat area of a clip angle, the following steps should be taken.

1. Determine the reaction,  $R$ , of the framing beam into the chord. (The chord is the through beam and the framing beam is the beam that is transferring load to the chord).
2. Since AIMS International's standard details requires two clip angles, one on either side of the framing beam, it is a correct assumption that each clip angle will transfer half the load, or  $R/2$ .
3. Using the thickness of the clip angle,  $t$ , and the depth of the clip angle,  $d$ , calculate the shear area,  $A_v$ .  $A_v = t \times d$ .
4. The allowable shear load,  $V_a$ , of each clip angle is calculated as follows:

$$V_a = F_v \times A_v \geq R / 2$$

5. If  $V_a < R/2$ , increase either the  $t$  or  $d$  as required to safely carry the load.

### Checking beam shear on the web of the beams and chords:

When checking beam shear on the web of the beams, the following steps should be taken:

1. From the framing beam shear diagram, determine the beam shear or reaction,  $R$ .
2. From Section 5, obtain the web shear area,  $A_w$ , where  $A_w = d \times t_w$  for the appropriate beam section, with  $d$  being the total depth of the beam section, and with  $t_w$  being the web thickness.
3. Calculate the allowable beam shear,  $V_a$ , of the beam in the following manner:

$$V_a = A_w \times F_v \geq R$$

4. If  $V_a < R$ , use a beam with more web shear area, and this is achieved by using a thicker web or by using a beam of greater depth, or both. An epoxied web doubler can also be used to increase shear area.



### Checking bolt bearing on the web of the beams:

When checking bolt bearing on the web of the beams or the clip angles, the following steps should be taken:

1. From the framing beam shear diagram, determine the beam shear or reaction,  $R$ .
2. Calculate the beam web bearing area,  $A_{brg}$ , as follows:

$$A_{brg} = t_w \times \emptyset_b \times (\text{number of bolts})$$

where  $\emptyset_b$  is the bolt diameter and  $t_w$  is the web thickness of the beam or clip angle(s). (Note: If calculating the bearing capacity of the clip angles, bear in mind that, since two clip angles are transferring the load,  $A_{brg}$  would be calculated by the formula:  $A_{brg} = 2 t_w \times \emptyset_b \times \text{number of bolts}$ ).

3. Calculate the allowable bearing capacity of the connection,  $P_{allow}$ , as:

$$P_{allow} = F_{brg} \times A_{brg} \geq R$$

4. If  $P_{allow} < R$ , the engineer must increase the bearing area, and this is achieved by a combination of, or all of the following----increase the number of bolts, increase the diameter of the bolts, increase the web thickness of the beam, or adding an epoxied bearing doubler plate, or the use of thicker clip angles if analyzing the bearing capacity of the clip angle system.

### Calculating bolt shear capacity, web of beams through the bolt:

When calculating the bolt shear capacity, the following procedures should be followed:

1. Using 316 SS bolts, calculate the allowable shear stress of the bolt,  $F_{vb}$  using the following:

From the AISC Steel Design Manual, for bolts with threads included in the shear plane,  $F_{vb} = 0.17F_u$ , and  $F_{vb} = 0.22F_u$  when threads are excluded from the shear plane, where  $F_u$  is the specified tensile strength of the bolt material. For 316 Stainless Steel,  $F_u = 75,000$  psi. Thus, for 316 SS bolts with threads in the shear plane,  $F_{vb} = 12,750$  psi, and 16,500 psi for 316 SS bolts with threads excluded from the shear plane.

2. Calculate the bolt shear area,  $A_{vb}$ , using the following:

$$A_{vb} = [(\text{number of bolts}) \pi (\emptyset_b)^2 / 4] \text{ for single shear, and}$$
$$A_{vb} = [(\text{number of bolts}) \pi (\emptyset_b)^2 / 4] \times 2 \text{ for double shear}$$

(Note: Typically, the shear condition will be double shear because of the fact that two clip angles are being used. However, if only one clip angle is being used, as is the case in special situations, then the single shear condition exists.)

3. Calculate the allowable shear capacity of the bolts,  $P_{\text{allow}}$ , using the formula:

$$P_{\text{allow}} = F_{\text{vb}} \times A_{\text{vb}} \geq R$$

4. If  $P_{\text{allow}} < R$ , then the problem can be remedied by either increasing the number of bolts, or by increasing the diameter of the bolts, or both.

### **Epoxied Connections**

When designing an epoxied connection, the engineer must realize that all flexibility for removal of the joint is being lost. However, if the choice to epoxy the joint is made, the following minimum guidelines should be followed.

Standard epoxies used in the industry possess an adhesion strength of 1,000 psi, and using a 4.0 Safety Factor as required in Section 6, the allowable adhesion,  $F_{\text{adh}} = 250$  psi. The capacity of the epoxied joint,  $P_{\text{allow}} = F_{\text{adh}} \times A_{\text{adh}} = 250 \text{ psi} \times A_{\text{adh}}$ , where  $A_{\text{adh}}$  is the surface area of the adhesion.

**Please note that the surfaces to be epoxied together must be prepared for epoxying in accordance with the epoxy manufacturer's recommended specifications.**

NOTE: The information presented in this brochure is believed to be accurate and reliable. However, it is based on test results which may not apply to your application. Therefore, the data is presented without guarantee or warranty. We recommend that you contact AIMS' engineering department or your local representative to discuss the details of your specific application.

Trademarks used herein:

Pultex®  
Superstud™  
Extren®

Creative Pultrusions, Inc.  
Creative Pultrusions, Inc.  
Strongwell, Inc.

# AIMS International, LLC

*... dedicated to customer service and support*

## **AIMS International, LLC**

1617 Peach Leaf St.

Houston, TX 77039

Phone 281.590.3240 ▪ Toll Free 800.495.5997

Fax 281.590.3773 ▪ [sales@aims-intl.com](mailto:sales@aims-intl.com)

[www.aims-intl.com](http://www.aims-intl.com)